

— AT THE SIGN OF THE CAT —



Mercury

APRIL MAY JUNE, 1983 Volume 4 Number 2

DEDICATED TO THE PRESERVATION
OF THE

67-73 Cougar

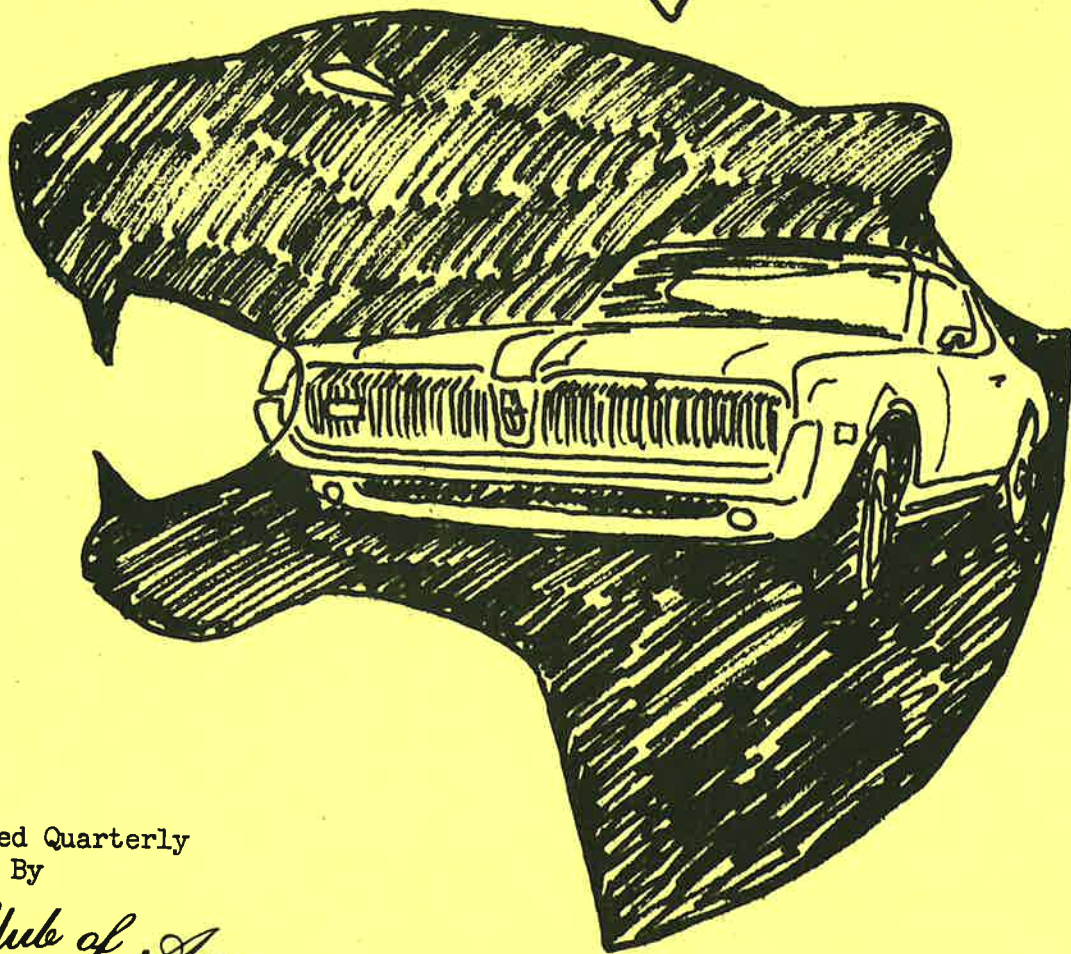

Published Quarterly
By

Cougar Club of America
1526 Ericson Place
Bronx N.Y. 10461

CLUB ITEMS

Available to Paid-up
Members

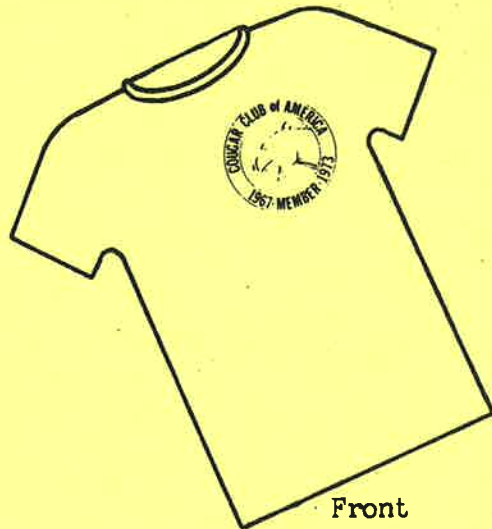

Front

Lt. Blue or
Dark Blue
T-SHIRT

\$8.00
(Postpaid)



Back



3 3/4"

JACKET PATCHES
DECALS

~~\$2~~ Postpaid
~~\$2~~ "

Order T-Shirts and Jacket patches from: Tom Jacobellis, 1526 Ericson Place, Bronx, NY 10461.
(Specify T-Shirt size) Also light or dark Blue.

PENS



Inscribed: Cougar Club of America, 1526 Ericson Place, Bronx, NY 10461, Mercury Cougars of
1967-1973, At The Sign of The Cat. (Blue ink-Blue Barrel)

50¢ ea. Postpaid

(~~18¢~~ Paid-up Members receive a Free Pen)

Order Pens from: Tom Jacobellis at C.C. of A.

These are very nice items that show you're proud of your
COUGAR.

Features included in this month's edition of "At The Sign of The Cat":

- ** Top Cat
- ** Coug's Corner
- ** Region #1 Update
- ** Dick Martin's Questions and Answers
- ** Jim Rakowsky's Car Inventory
- ** Member Photos
- ** "Cat Eyes" (Headlamp Repair)
- ** "D.C." Cougs

* * *

TOP CAT

BY TOM JACOBELLIS

Our club continues to grow and become stronger. Remember the club is here for the members! There is little to report this month other than to remind members of the upcoming national meet in Omaha, August 13 and 14. Remember to watch National Director's column for further information as it develops, as well as info on regional mini-meets. Hope to see you at least one of these!

Dick Martin will assist Editor Mike Berry as co-editor. For the time being Dick will remain as technical director. However any interested in assuming this job should contact me or Dick. We'd like to divide this into three areas of expertise: electrical, mechanical and body.

In future issues I'll be doing reviews on books of interest to Cougar owners. Might I also remind members not to contact Bill Veach for any back copies, but rather myself -- but bear in mind such copies are quite limited in number.

Rob Theiss (#534) would appreciate any information any of you might have on a '67-68 white Cougar which appeared in a recent movie "A Lovely Way to Die" starring Kirk Douglas and Eli Wallach.

* * *

LAST MAY'S VIRGINIA MEET:



Finally, don't forget to send picnic locations to Mike Berry. Material should reach Mike by early June for inclusion in the July "Cat".

* * *

Club Historian
Jim Rakowsky with
"Top Cat" Tom J.



Tom with Barrie
and Jeanette Dixon
of England.



"COUG"

* * *

COUG's CORNER

Well as we go to press with this, our Spring issue, Spring is certainly in the air. As such, might I remind members to send in picnic locations for the summer season. Also, with the warm weather just around the corner, this issue we feature articles by Dick Martin on headlight operation

to assist the backyard and driveway mechanics! Also Jim Rakowsky, club historian, contributes an inventory of club cars. As well Region #1 director Randy Goodling sends a Region #1 Update for northeast members.

Dorothy and Randy Minniear, #481 of Lafayette, Ind., write of a book on '67 Cougars called "'67 Mercury Cougar - How and Why?". It is available for \$4.95 from Autobooks Unlimited, Box 9, Ft. Calhoun, Nevada, 68023.

Finally, an article on Cougars including some twenty pictures in the June, 1983 issue of Special Interest Autos magazine could be interesting. The magazine is available on newstands only so keep your eyes open.

Remember keep the articles and information coming -- we try to print all we can!!



REGION #1 UPDATE

Spring is just around the corner and when we turn that corner, our cats will once again be on the prowl. Ah, but what is there to do with your cat, just drive around by yourself? Well, that might do for a while, but sooner or later your cat will yearn to be with others of its kind. Now when your cat gets that fever, relax for there is a cure. I have been busy here in Region #1 seeking out places and events where your cat can achieve this happiness. Listed below are the dates and places where your cat can be treated.

July 9, 1983 - Cecil County Dragway, Rising Sun, Md. There will be a Ford only meet sponsored by Performance Ford Club of America, Upper Chesapeake Bay Region. There will be a Ford Car Show and drag racing. The gates will open at 9:00 am. The cost is \$4.00 for general admission (50% discount to PFCA members). The highlight of the drag racing will be a Super Pro Gas Match Race between a Mustang and a Camaro.

September 18, 1983 - East Coast Mini-Meet, R & J Ford, Lebanon, Pa. There will be a Ford only car show sponsored by Lebanon Valley Mustang Association - Penn Central SAAC (Shelby Club). There will be a Cougar only class. There will be dash plaques and door prizes. Wooden plaques will be given out to the winners of each class. The more Cougars in attendance, the more plaques that will be awarded. Winners are determined by popular vote. The show starts at 9:00 am. R & J Ford is on Route 422 near Route 72. Pre-registration is \$3.00 and \$5.00 the day of the show. If you wish to pre-register, make your cheque payable to L.V. Mustang-P.C. SAAC and send it to Randy Ream, 1817 Janet Avenue, Lebanon, Pa., 17042. It should be noted with your pre-registration that you learned of this show through the Cougar Club.

For those of you whose cats are in need of parts:

June 16-19, 1983 - Carlisle, Pa., Summer Carlisle Collector Car Flea Market and Car Corral.

September 29-October 2, 1983 - Carlisle, Pa. Fall Carlisle Collector Car Flea Market and Car Corral.

Well now that you know how to cure your cat, what's stopping you. Attend these meets. You will find that not only will your cat feel better, so will you. Let's get out and show the world that our cats are alive and doing fine. It's up to you as the membership to support these meets, they have been set up with you in mind and will mean nothing if you do not support them. I will be at all these functions and will be looking forward to meeting with all of you. If you have any questions, please contact me.

Randy Goodling,
Director, Region #1.

ATTENTION MIDWEST C.C.A. MEMBERS !!

Iola, Wisc., entertains one of the largest car shows July 9 & 10. Last year, five Cougars assembled (two members) out of over 3,000 show cars. Let's get together for a strong representation! For more information please write Jim Severson, 959 Gilrust Ave., Stoughton, Wisc., 53589., (#665)

** Accomodations must be made soon for anyone staying more than one day. **

* * *

QUESTIONS AND ANSWERS WITH DICK MARTIN:

Q. I have a 351C and will have to rebuild it soon, what about a mail order engine replacement? #891

A. Many rebuilding companies are very good and advertise semi-low prices, but most don't include freight/shipping, or a close dealer rep in case you get a bad one. My advice - find a quality rebuilder in or near your home town. I believe it will be cheaper in the long run, plus it will be easier if you have a problem.

Q. The window glass in my '69 Cougar keeps falling out - why? #1437

A. The window track surface tends to get gummed up or corroded. Clean, sand, scrape inside of track till clean and shining. Clean with lacquer thinner then apply a quality contact cement to track inside rails and window glass bottom edge - should be perfect seal, use C5AZ-19554-A.

Q. My '67 XR-7 has a light problem - the door lights go on and off with the doors closed - why?

A. Your headlight switch sounds bad or you might check one of your toggle switches on your dash (centre).

Q. My '69 Cougar's signal flashers slow down then speed up when I give it gas.

A. **1) new flasher bulb on fuse box
2) check grounds/fuses (size)
3) bad turn signal bulb(s)
4) last - voltage regulator (doubtful)

Q. Where can I buy some Eliminator stripes for '69 Cougar?
A. Write to Tom J.

Q. Where can I buy some rear window louvers for my '68 Cougar?
A. Sports Shades at 360 Highland Ave., Passaic, N.J., 07055, offers louvers for 1967-73 Cougars for \$83.00 a set. Tell them you're a Club member and get a discount.

Q. I have a '68 Cougar that misses out at high speeds - the engine has 75,000 miles on it. I've checked the coil, wires, carb and installed a new timing chain, etc.

A. Sounds like a bad distributor with bad bearings - you're getting shaft wobble at high speeds.

CLUB CAR INVENTORY By Jim Rakowsky, Club Historian

I've been keeping the Cougar Club records for two years now, and I thought that it's time I publish a summary.

I have individual records on 1,056 Cougars of 1967 to 1973. The information you provide on the membership form is my source, namely, serial number and door tag or owner card data or color, date, interior, axle, trans, and DSO.

Some members' cars are not yet included in the statistics because they did not complete even the serial number information. Also included are records on non-member Cougars, those I find in junkyards or on the street. Of the 1,056 Cougars on file 152 have been scrapped or parted out. If you locate junkyard Cougars in your travels jot down the serial number and other data and send it to me.

I've broken down the summary by year and model with the production figures. Please not on row 4 for 1968 that I've listed the XR-7Gs and GTE's on the same line. There were an unknown number of 7.0 litre GTEs made. Most had the 427 4V, a couple got the 428CJ later in the year. We do know that there were 304 XR-7Gs made with a variety of engines (except the 427s).

There are 8 GTEs in the club, 7 with 427s and 1 with a 428. The other 21 "X" cars on row 4 are XR-7Gs. If anyone has further information on the XR-7Gs or GTEs let me know.

It's interesting to note that while Cougars came standard with 3 spd manual transmissions that only 33 (3%) of the cars in the club have it, while only 53 (5%) have 4 spds.

These statistics are as of December, 1982:

1967:	289-2V	289-4V	390GT	Totals	Prod. Figures					
Std. Hdtp	82	36	12	130	116,260					
Bench S.Htp.	3	0	1	4	7,412					
XR-7 Hdtp	30	19	14	63	27,221					
1968:	289-2V	302-2V	302-4V	390-2V	390GT	4274V	428CJ	Tot	PrdFig.	
Std Hdtp	30	20	56	1	6	0	0	113	78,337	
Bench S.Htp	0	0	1	0	1	0	0	2	2,677	
XR-7	0	22	51	5	21	0	2	101	32,408	
GTE &XR-7G	0	4	2	0	14	7	2	29	?+304	
1969:	351-2V	351-4V	390GT	428CJ	428CJr.	a.Bs302	427-4	Tot	PrdFig.	
Std. Hdtp	109	6	4	0	3	0	0	122	62,305	
Bench seat	4	1	0	0	1	0	0	6	1,615	
Convvt	44	7	0	0	0	0	0	51	5,796	
XR-7 Hdtp	49	24	5	3	5	0	0	86	23,918	
XR-7 Conv	31	22	8	3	2	0	0	66	4,024	
Eliminator	0	15	2	1	4	3	1	26	2,411	
1970:	351-2V	351-4V	428CJ	Boss302-4V	Totals	Prod.Fig.				
Std. Hdtp	31	3	1	0	35	47,279				
Convvt	19	1	0	0	20	2,322				
XR7 Hdtp	24	3	1	0	28	18,565				
XR7 Conv	12	11	2	0	25	1,977				
Eliminator	0	19	6	9	34	2,200				

1971:	351-2V	351-4V	429CJ	Totals	Prod. Figures
Std. Hdtp	10	1	0	11	34,008
Conv.	4	0	1	5	1,723
XR7 Hdtp	5	3	0	8	25,416
XR7 Conv	7	5	0	12	1,717
1972:	351-2V	351-CJ		Totals	Prod. Figures
Std. Hdtp	4	0		4	23,731
Conv.	8	0		8	1,240
XR7 Hdtp	8	0		8	26,802
XR7 Conv	7	1		8	1,929
1973:	351-2V	351-CJ		Totals	Prod. Figures
Std. Hdtp	5	0		5	21,069
Conv.	3	0		3	1,284
XR7 Hdtp	13	3		16	35,110
XR7 Conv	18	7		25	3,165

* * *

"CAT EYES": 1967-68 by Dick Martin

The single most asked question of me is "what's wrong with my headlight covers?" Having done some research on the problem I've found an easy step by step problem solver that Fo Mo Co for some reason created that makes sense to us. This article examines the major problem with this system, namely the vacuum motors behind the covers.

I have yet to understand why they chose vacuum to operate them. No doubt a sealed single electric motor would have been more reliable and cheaper. Evidently Ford's experiences with the 1957-59 Ford retractable caused them to be gun shy of electric systems of this nature.

If you follow this article step by step you should be able to solve all your problems. Write me if you have a problem. Next ... 69-70 Cougar headlamps. (cont'd p. 7)

* * *

CAT TRACKS TECHNICAL COLUMN

BY DICK MARTIN

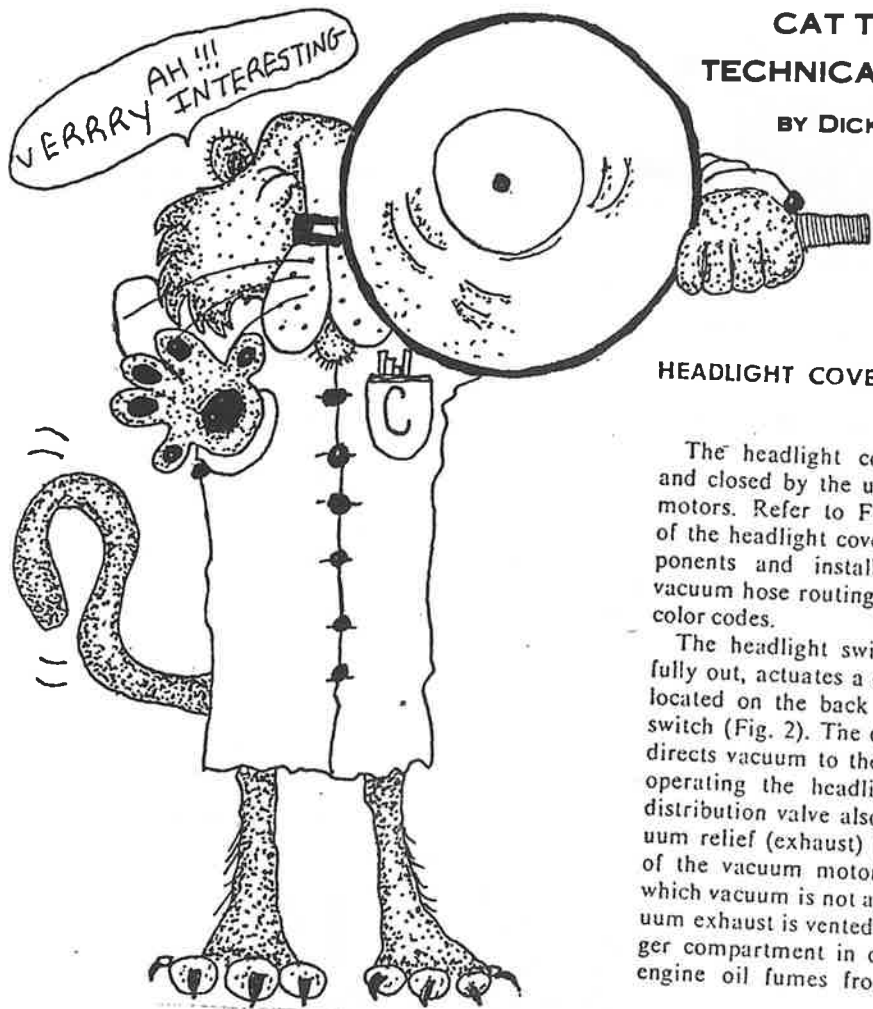

HEADLIGHT COVERS—COUGAR

The headlight covers are opened and closed by the use of two vacuum motors. Refer to Fig. 1 for location of the headlight cover operating components and installation. Note the vacuum hose routing, connections and color codes.

The headlight switch, when pulled fully out, actuates a distribution valve located on the back of the headlight switch (Fig. 2). The distribution valve directs vacuum to the vacuum motors operating the headlight covers. The distribution valve also provides a vacuum relief (exhaust) port to that side of the vacuum motor diaphragms to which vacuum is not applied. The vacuum exhaust is vented into the passenger compartment in order to prevent engine oil fumes from entering the

distribution valve. Early production vehicle headlight covers are equipped with an external hinge spring, attached to each cover. The spring functions as an over center type spring, and helps to hold the covers in the open or closed position. Vacuum applied to either side of the vacuum motor diaphragm during opening or closing, overcomes this spring tension.

On later production vehicles, the headlight control motors will be equipped with an internal spring instead of cover springs. The internal spring will automatically open the headlight covers in the event the vacuum system should fail.

A vacuum reservoir provides vacuum storage which permits limited cycling of the headlight covers without the engine running.

In case of a vacuum loss the headlight covers, equipped with external springs, can be opened or closed manually. To open the covers, pull the headlight switch all the way out and lift the covers by hand. To close the covers, push the headlight switch all the way in and close the covers by hand.

The headlight covers should be opened (raised) when washing the car to clean the headlights for safer nighttime driving.

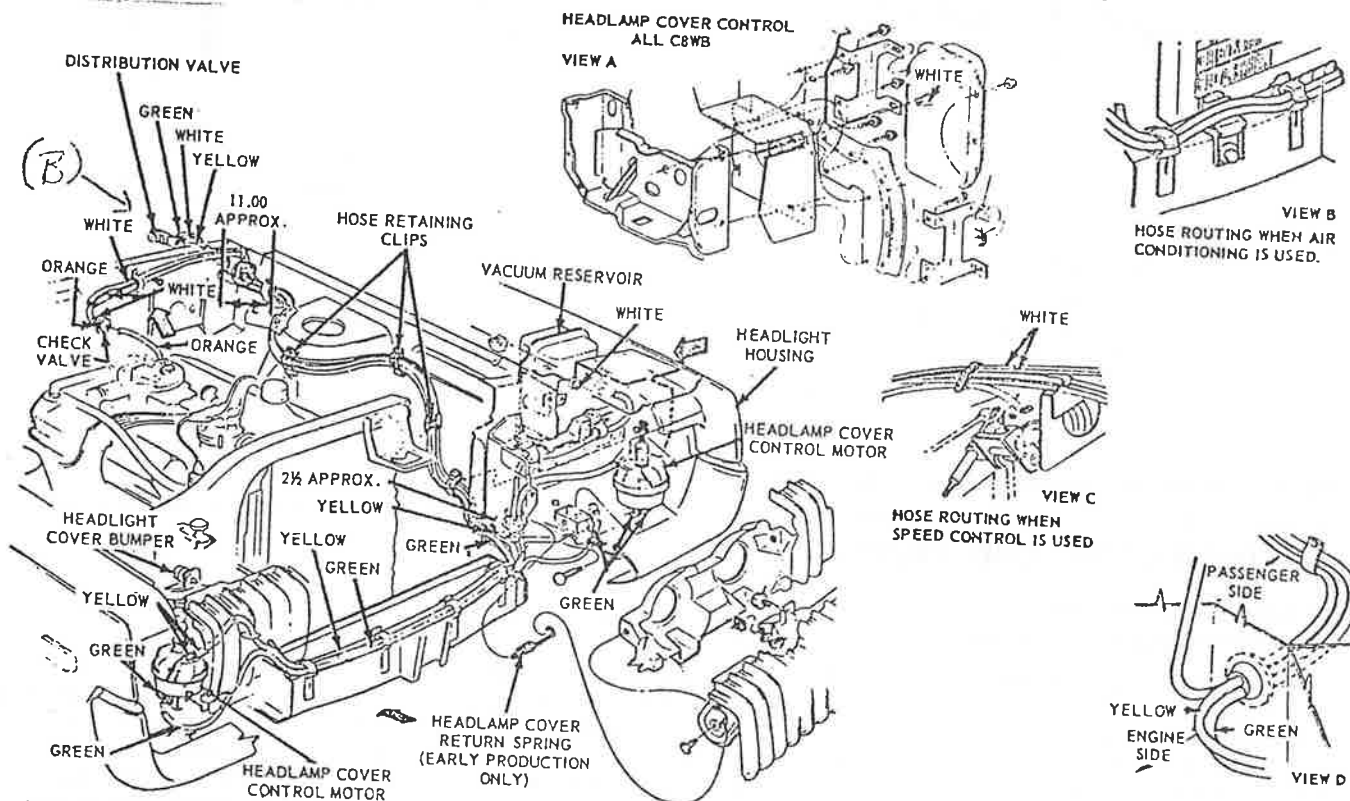

FIG. 1 — Headlight Cover Vacuum System-Cougar

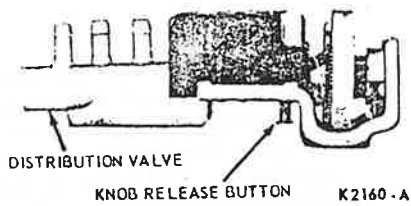

FIG. 2 — Headlight Switch (with Distribution Valve)

HEADLIGHT SWITCH

A combination headlight switch and two circuit breakers is used (Fig. 3). The headlight circuit is protected by an 18 ampere circuit breaker for the Montego, Falcon, Cougar and Fairlane, a 12 ampere circuit breaker for the Mustang. The tail, parking, license plate light, marker light, ignition switch light, and horn circuits are protected by a 15 ampere circuit breaker.

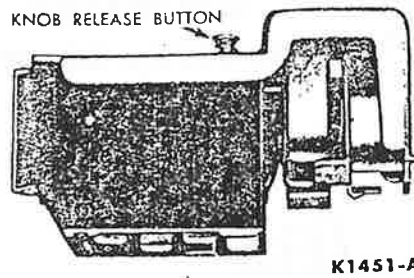

FIG. 3 — Headlight Switch

MECHANICAL STOP LIGHT SWITCH

The mechanical stoplight switch differs from the hydraulic switch formerly used. The switch assembly is installed on the pin of the brake pedal arm so that it straddles the master cylinder push rod. The switch assem-

bly is a slip fit on the pedal arm pin and thus the switch assembly moves with the pedal arm whenever the brake pedal is depressed.

The brake pedal arm pin has a designed-in clearance with the eye of the master cylinder push rod (Fig. 4). Because of this clearance, whenever the brake pedal is pushed forward, the stop light switch contacts, moving with the pedal arm, are actually pushed against the end of the master cylinder push rod, through the switch actuating pin. It is this movement of the switch with respect to the actuating pin and master cylinder push rod that closes the switch contacts completing the circuit to the stoplights.

When the brake pedal is released, the spring in the stop light switch returns the actuating pin to its normal position and the circuit to the stop lights opens.

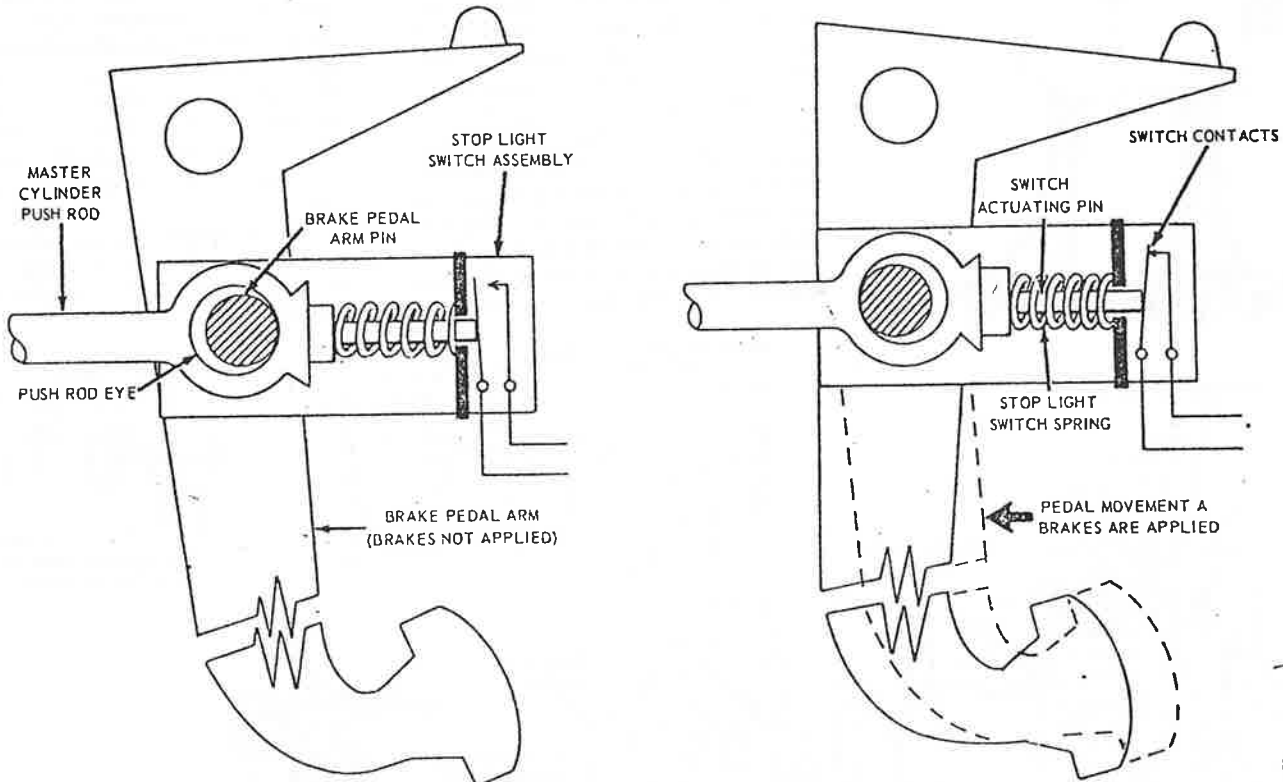

Fig. 4 — Mechanical Stop Light Switch Operation

2 DIAGNOSIS AND TESTING

HEADLIGHT COVER TROUBLE DIAGNOSIS GUIDE—COUGAR

Before performing a vacuum check on the headlight cover system, check the mechanical components and operation of the headlight covers (refer to Fig. 1, Section 1). Also check to see that all hoses are properly connected to the system components and do not

have any kinks that would impair the operation of the system.

During the performance of the diagnosis procedure, it will be necessary to consult Fig. 6 for location of the proper check points. Also, it will be necessary to read the Vacuum Test Probe procedure in this section for fabrication and use of the vacuum

probe to diagnose the headlight cover system.

The diagnosis guide has been coded to allow for easier use. The major steps have been coded A1, A2, B1, B2, etc. After the initial check has been made, the code allows for quicker selection of the proper step in isolating the faulty component.

ALL HEADLIGHTS DO NOT LIGHT	Verify the complaint. 1. Loose battery cable. 2. Loose quick disconnect or broken wire from the battery to the headlight switch. 3. Defective headlight switch. 4. Disconnected or broken wire from the headlight switch to the beam selector switch.	5. Loose or broken wire to the bulbs. 6. Defective beam selector switch. 7. All headlight bulbs burned out. This may be caused by a defective or improperly adjusted alternator voltage regulator (Group 13).
INDIVIDUAL LIGHTS DO NOT LIGHT	Verify the complaint. 1. Burned out bulb. 2. Loose or broken wires to the bulb.	3. Poor ground.
LIGHTS BURN OUT REPEATEDLY	Verify the complaint. 1. Loose or corroded electrical connections. 2. Excessive vibration.	3. Improperly adjusted or defective alternator voltage regulator (Group 13).
BOTH LOW BEAM HEADLIGHTS DO NOT LIGHT	Verify the complaint. 1. Defective beam selector switch. 2. Loose or broken wire to the bulbs.	3. Both low beam filaments burned out.

FIG. 5—Headlight Trouble Diagnosis Guide

VEHICLES WITH EXTERNAL SPRINGS ON HEADLIGHT COVERS

ONE HEADLIGHT COVER DOES NOT OPERATE

Verify the complaint. Check for vacuum through the green hose at the cover motor that does not operate.

If Cover Motor Green Hose Not Ok

Check for vacuum at point I or J through the tee (Fig. 6).

If Check OK

Repair or replace the green hose between the tee and the motor.

If Check Not OK

Repair or replace the tee in the open (green) circuit.

If Cover Motor Green Hose OK

Remove the yellow hose from the effected cover motor. The cover should raise.

If Cover Check Not OK

Replace the cover motor, or check for an interference of the cover mechanism.

If Cover Check OK

Apply vacuum to the tee end of the yellow hose, point L or M (Fig. 6), that connects to the cover motor. Turn OFF the headlight switch. The cover should close.

If Yellow Hose Check Not OK

Repair or replace the yellow hose between the cover motor and the tee.

If Yellow Hose Check OK

Repair or replace the tee in the yellow (close) circuit.

HEADLIGHT COVERS DO NOT OPERATE WHEN ENGINE IS RUNNING OR WHEN ENGINE IS OFF

Verify the complaint. Start the engine and check for vacuum at the connector at point D.

A1 If Point D Check Not OK

Cap the connector at B and recheck for vacuum at connector D (Fig. 6).

If Recheck At D Not OK

Check for vacuum through the hose at point C.

If Hose Vacuum Not OK

Repair or replace the hose between points C and R.

If Hose Vacuum OK

Replace the check valve.

If Recheck at D OK

Perform a leak test on the reservoir.

If Reservoir Leak Test Not OK

Replace the reservoir.

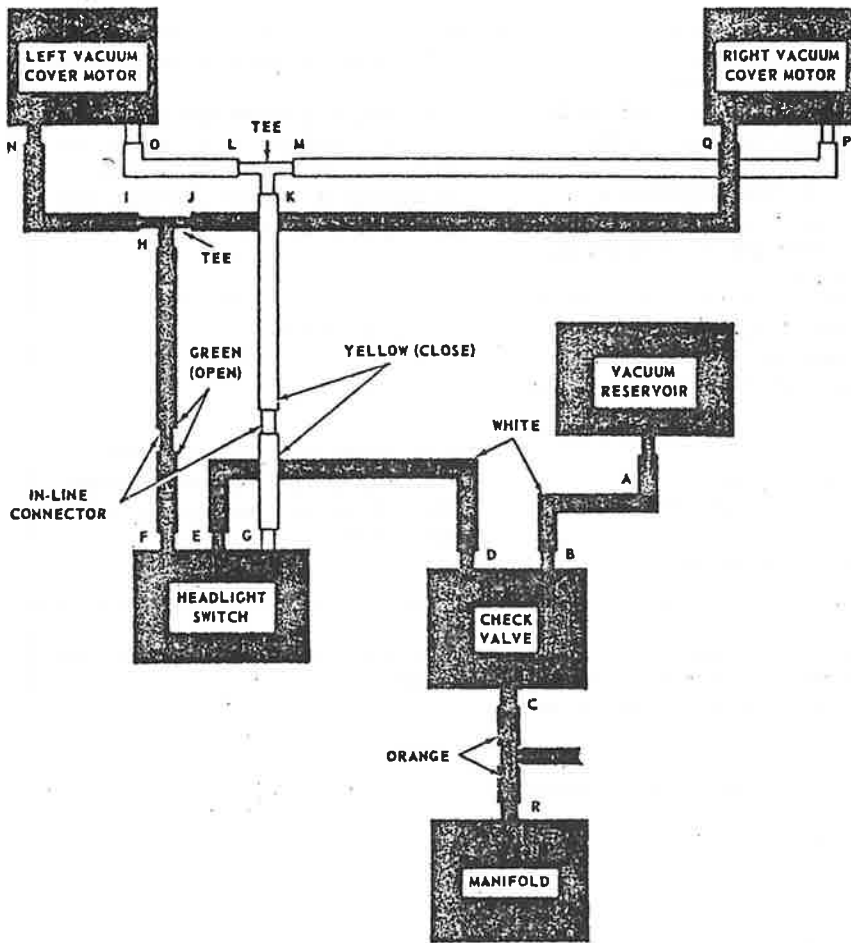

K 2188-A

FIG. 6—Headlight Cover Vacuum System—Cougar

If Reservoir Leak Test OK

retest the hose at point D.

Repair or replace the hose between points A and B.

C1 If Retest At Point D Not OK

Leak test the connector at point H.

A2 If Point D Check OK

Turn the headlight switch ON and leak test the hose at point D.

If Leak Test At Point H Not OK

Leak test both cover motors and replace as required.

B1 If Hose Leak Test At Point D Not OK

Turn the headlight switch OFF and

If Leak Test At Point H OK

Check for vacuum through the hose at point E.

Repair or replace the hose between points D and E.

If Vacuum At Point E OK

Perform a leak test at the headlight switch (Refer to Headlight Cover Vacuum System Leak Test in this section).

If Headlight Switch Test Not OK

Replace the headlight switch.

If Headlight Switch Test OK

Repair leaks in the OPEN and CLOSE circuits.

C2 If Retest At Point D OK

Perform leak test at the connector H.

D1 If Leak Test At Point H Not OK

Perform leak test on the hose at point I.

If Leak Test At Point I Not OK

Leak test the left cover motor at point N.

If Left Cover Motor Not OK

Replace the cover motor.

If Left Cover Motor OK

Repair or replace the hose between points I and N.

If Leak Test At Point I OK

Perform the leak test on the right cover motor at point Q.

If Right Cover Motor Not OK

Replace the right cover motor.

If Right Cover Motor OK

Repair or replace the hose between points J and Q.

D2 If Leak Test At Point H OK

Perform leak test on the hose at point F.

If Leak Test At Point F Not OK

Repair or replace the hose between points F and H.

If Leak Test At Point F OK

Replace the headlight switch.

B2 If Hose Leak Test At Point D OK

Check for vacuum through the yellow hose at either cover motor.

E1 If Yellow Hose At Cover Motors Not OK

Check for vacuum through the hose at point E.

If Vacuum At Point E Not OK

Repair or replace the hose between points E and D.

If Vacuum At Point E OK

Check for vacuum at connector G.

If Vacuum At Point G Not OK

Replace the headlight switch.

If Vacuum At Point G OK

Repair or replace the hose between point G and the cover motors.

E2 If Yellow Hose At Cover Motor OK

Turn the headlight switch ON and check for vacuum through the green hose at either of the cover motors.

If Green Hose Check Not OK

Check for vacuum at connector F.

If Vacuum At Point F Not OK

Replace the headlight switch.

If Vacuum At Point F OK

Repair or replace the hose between F and the cover motors.

If Green Hose Check OK

The venting holes on the headlight switch are plugged, repair as necessary.

B3 If Hose Leak Test At Point D Not OK

Perform a leak test at connector K.

F1 If Leak Test At Point K Not OK

Perform leak test on hose at point L.

If Leak Test At Point L Not Ok

Perform leak test on the left cover motor at point O.

If Left Cover Motor Leak Test Not OK

Replace the left cover motor.

If Left Cover Motor Leak Test OK

Repair or replace the hose between points L and O.

If Leak Test At Point L OK

Perform leak test on the right cover motor at point P.

If Right Cover Motor Leak Test Not OK

Replace the right cover motor.

If Right Cover Motor Leak Test OK

Repair or replace the hose between points M and P.

F2 If Leak Test At Point K OK

Perform a leak test on the hose at point G.

If Leak Test At Point G Not OK

Repair or replace the hose between points G and K.

If Leak Test At Point G OK

Replace the headlight switch.

**HEADLIGHT COVERS
OPERATE WHEN ENGINE
IS RUNNING BUT NOT
WHEN ENGINE IS OFF**

Verify the complaint. Turn OFF the headlight switch. Insert a vacuum gauge into the system at point D. Start the engine and allow it to run for approximately one minute to fill the vacuum reservoir. Turn the engine off and check for a minimum of 14 inches of steady vacuum.

A1 If Point D Vacuum Reading Not OK

Perform a leak test on the hose at point D (Fig. 6).

If Leak Test At Point D Not OK

Turn ON the headlight switch and repeat the leak test at point D.

B1 If Second Leak Test Not OK

Perform a leak test at connector H.

If Leak Test At Connector H Not OK

Perform a leak test at each of the cover motors and replace the motor(s) as required.

If Leak Test At Connector H OK

Check for vacuum through the hose at point E.

Repair or replace the hose between points D and E.

If Vacuum Check At Point E OK

Perform a leak test on the headlight switch.

If Headlight Leak Test Not OK

Replace the headlight switch.

If Headlight Leak Test OK

Repair any leaks in the OPEN and CLOSE hose circuits.

B2 If Second Leak Test OK

Perform a leak test at the connector K.

C1 If Leak Test At Connector K Not OK

Perform a leak test on the hose at Point L.

If Leak Test At Point L Not OK

Perform a leak test on the left cover motor at Point O.

If Leak Test On Left Motor Not OK

Replace the left cover motor.

If Leak Test On Left Motor OK

Repair or replace the hose between points O and I.

If Leak Test At Point L OK

Perform a leak test on the right cover motor at point P.

If Leak Test On Right Motor Not OK

Replace the right cover motor.

Repair or replace the hose between points M and P.

C2 If Leak Test At Connector K OK

Perform a leak test on the hose at point G.

If Leak Test At Point G Not OK

Repair or replace the hose between points G and K.

If Leak Test At Point G OK

Replace the headlight switch.

If Leak Test At Point D OK

Perform a leak test on the hose at point B.

If Leak Test At Point B OK

Repair or replace the check valve.

If Leak Test At Point B Not OK

Perform a leak test on the vacuum reservoir.

If Reservoir Test Not OK

Repair or replace the vacuum reservoir.

If Reservoir Test OK

Repair or replace the hose between points A and B.

A2 If Point D Vacuum Reading OK

With the vacuum gauge still at point D, turn the headlight switch ON and check for 14 inches of steady vacuum.

D1 If Vacuum Check With Headlight Switch On Not OK

Perform a leak test at connector H.

Perform a leak test on the hose at point I.

E1 If Leak Test At Point I Not OK

Perform a leak test on the left cover motor at point N.

If Left Cover Motor Leak Test Not OK

Replace the left cover motor.

If Left Cover Motor Leak Test OK

Repair or replace the hose between points I and N.

E2 If Leak Test At Point I OK

Perform a leak test on the right cover motor at point Q.

If Right Cover Motor Leak Test Not OK

Replace the right cover motor.

Repair or replace the hose between points J and Q.

If Leak Test At Connector H OK

Perform a leak test on the hose at point F.

If Leak Test At Point F Not OK

Repair or replace the hose between points F and H.

If Leak Test At Point F OK

Replace the headlight switch.

D2 If Vacuum Check With Headlight Switch On OK

Apply vacuum to the connector at H. The headlight covers should open.

*Car Show
Information
pullout Section*



*Ben Leone
Membership # 1574*

ARTICLE VI
JUDGING STANDARDS

The purpose of Article VI is to establish the standards for judging Cougar Automobiles entered in competition at CCOA events. The judging form shall be as in Attachment I.

Judging Classes

Judging classes shall be as follows:

Class I	1967-1968	Original Vehicles, all models
Class II	1967-1968	Modified Vehicles, all models
Class III	1969-1970	Original Vehicles, hardtop models
Class IV	1969-1970	Original Vehciles, convertible models
Class V	1969-1970	Modified Vehicles, hardtop models
Class VI	1969-1970	Modified Vehicles, convertible models
Class VII	1971-1973	Original Vehicles, hardtop models
Class VIII	1971-1973	Original Vehicles, convertible models
Class IX	1971-1973	Modified Vehicles, hardtop models
Class X	1971-1973	Modified Vehicles, convertible models

For each class above, there shall be three divisions if applicable as follows:

- Division A - Standard Models
- Division B - XR-7 Models
- Division C - Special Production Models

Definitions

Original - An original Cougar, as represented by the owner, shall be a Cougar automobile that is unaltered from the configuration when new, except for maintenance items such as engine parts, tires, etc, subject to authenticity deductions in judging.

Modified - A modified Cougar, as represented by the owner, shall be a Cougar automobile that has been altered from the configuration when new. Examples include engine and chasis parts not produced by Ford Motor Company and not commercially available from a factory dealer source.

Special Production - Specifically to include Cougar GT, GTE, Eliminator, Dan Gurney, and other applicable promotional models.

THE ABOVE JUDGING RULES WERE DRAFTED BY DICK HERTZLER, 7204 DANNY LANE, MANASSAS, VA. 22111. IF YOU AGREE, DISAGREE OR HAVE ANY IDEAS OF YOUR OWN ON THESE RULES PLEASE LET DICK KNOW AS SOON AS POSSIBLE SO WE CAN HAVE A SET OF RULES FOR THE CAR MEETS THIS YEAR.

Cougar Club of America

Fellow Members:

For you as a true "Cougar Fanatic" this will be the second of three very important newsletters. The third will be in July.

The Nationals

Sapp Brothers Ford will sponsor this year's event. Sapp Brothers is located 15 miles west of downtown Omaha, NB, on I-80 at exit #440. They are a very large dealership with a big lot and large new building with loads of inside space for a huge swapmeet. Sapp Brothers is going to push a large TV and newspaper campaign for the show during the summer in the Omaha area. This should draw a huge crowd.

Accomadations:

1) Ben Franklin Motel-has a pool, is located within a $\frac{1}{2}$ block.
2) Hi-Way House- also has a pool, is located within a mile (Exit 439).
Both of these motels have set aside a block of 50 rooms each. The cost will be \$29.95 for a room with 2 double beds for up to 4 people. Pay strict attention to the following:

a) These rates will apply only until July 15.

b) You will get the reduced rates only if you say you are with the Mustang-Cougar Meet.

c) You must call them to make you own reservations. The telephone numbers are: Ben Franklin Motel 402-895-2200. Hi-Way House 402-332-3911. For those of you who wish to make other arrangements, you will also find in this issue a list of motels and hotels in the Omaha area. If you have a problem in getting into either of the first two motels, let me know immediately so that I can have them set aside another block of rooms. My number 712-546-4214. Remember:

You must call for reservations before July 15th and say you are with the Cougar-Mustang Show. Also the rooms are on a first come, first serve basis, so be early.

d) For those of you with Campers, vans, fifth wheelers, etc., there is a camp-ground with hook-ups at exit # 432.

Activities: Car Show Aug. 13th and 14th.

Aug.13th. All Ford Drag Day--as long as you want. Evening "Hog Roast".

Aug 14th Cougar and Mustang Judge Show.

Swap meet both days- inside. For anyone wanting to come in early, I will be there on the 12th. A more complete list in the July issue.

Fees:

Drag race entry fee: \$25.00 per car. Strip open 10 to 4.

Show: Pre-registration, Per car \$6.00 Day of Show \$8.00

Vendor \$10 per swap space, appr. 12'x 15'.

Registration:

Because of the number of cars that are expected, I must have early registration to determine class break-down for trophies, number of dash plaques, etc. So enclosed is an entry blank which you must fill out and return to your regional director or myself by June 15, at the latest.



"At the Sign of the Cat"

Cougar Club of America

Mini-Meets:

A) Mini-meet East: Sept. 18, 1983. R&J Ford, Lebanon, Pa. contact Randy Goodling now for info. See Region #1 section for this as well as other region #1 meet information.

B) Mini-meet West: Sept. 1, 2, & 3. Sears Point, Calif. Contact Jim Dresbach, regional director, Region #5 for info. now.

Regional News:

I wish to say at this time that Region #3 now has a director:

Don Rasmussen # 1237
6145 Mullan Rd. #7
Missoula, Mont. 59802

State Directors:

Arizona- Kevin Marti
California- Jim Dresbach
Florida- Steve Shore
Georgia- John Stepp 3763 Gloucester Dr. Tucker, GA. 30084
Iowa- "my self"
Illinois- Harry Hodson
Indiana- Gary Miller 309 East 11th St. Jonesboro, Ind. 46938
Montana- Don Rasmussen 6145 Mullan Rd. #7 Missoula, Mont. 59802
North Carolina- Ken Barnette 628 Cooper Dr. Charlotte, N.C. 28210
New Jersey- Steve Salesky 10 Woodbridge Dr. Marlton, N.J. 08053
Oregon- Larry Juhnke
Pennsylvania- Randy Goodling
Texas- Tress Wright.

I would like to apologize to those members from Hawaii and Alaska for not putting you in a region. Therefore, Hawaii Region #5. Alaska, Region #4. To those members in Canada, I could use someone there as well to direct.

If any of you would like to see a get together held in your state or region get in touch with your state director or if you would like to pool rides to the Nationals or Mini-Meets, once again contact your state director. They have a list of members in your state. If you wish to know who and where the members are, ask them for a copy and they will send it to you. If your state doesn't have a director get in touch with the regional director, because they also have a list of members, by state.

Bits and Pieces:

For any one interested, John Paradise of Super Ford Magazine and Chris Halla are each putting together books on "Cougars" and need pictures of 67-73 Cougars. The Address to write:

Cougar Photos
% Super Ford Magazine
188 Ovid Street
Seneca Falls, N.Y. 13148

Chris Halla
445 West Hill Street
Spring Green, Wisc. 53588
(must have by first week in May)

In this letter is a class breakdown for judge shows as taken from the club constitution--one can easily see from the list why I must have early registration.



"At the Sign of the Cat"

Cougar Club of America

If there is an interest, a model car contest is being planned for Omaha (Ford's and Mercury only!)

Along those lines, my son needs a '67 Cougar model whether it be dealer promo or plastic to complete his collection from 67-73 Cougars. If you have such an item bring it along to Omaha or contact us.

One dash plaque will be included with your registration fee for the National Meet.

Last pages of the letter contain meet info, so pay close attention.

My family and I are looking forward to seeing and meeting lots of Cougar owners and fans in Omaha. We are sure you will find it a great weekend for your entire family. Be sure to call or write if you have any suggestions or questions.

Yours truly, a Cougar Fan,



Rod LaBahn, National Director
Cougar Club of America
610 3rd Ave. S.E.
LeMars, Iowa 51031
712-546-4214



"At the Sign of the Cat"

Cougar Club of America

NATIONAL MEET SAPP BROTHERS FORD, OMAHA, NB.
Aug. 13 and 14, 1983

PRE-REGISTRATION FORM

NAME _____

ADDRESS _____

CLUB NUMBER _____ CAR MODEL _____ YEAR _____

ORIGINAL _____ or MODIFIED _____

SPECIAL OPTIONS _____

I have enclosed check for Registration Fee _____

Vendor Fee _____

Drag Race Fee _____

TOTAL _____

Make check payable to Cougar Club of America.

**RELEASE FORM: IF YOU ARE ATTENDING ONE OF THE C.C.A. MEETS THIS YEAR
YOU MUST SIGN ONE OF THESE FORMS.**

I, THE UNDERSIGNED, AGREE THAT I WILL NOT HOLD THE COUGAR CLUB OF AMERICA OR ITS REPRESENTATIVES, CO-SPONSORING CLUBS OR SAPP BROS. FORD RESPONSINLE FOR PERSONAL OR PROPERTY DAMAGE TO MYSELF OR MY VEHICLE. I UNDERSTAND THAT THE C.C.A. HAS DONE ALL THAT IS POSSIBLE TO INSURE THE SAFETY OF MYSELF AND MY VEHICLE. I PARTICIPATE OR MY OWN FREE WILL AND UNDERSTAND WHAT I AN SIGNING.

DRIVERS SIGNATURE _____

PASSENGERS SIGNATURE 1) _____

2) _____ 3) _____

4) _____ 5) _____

WITNESS _____ DATE _____



"At the Sign of the Cat"

OMAHA'S HOTELS/MOTELS AND MOTOR INNS

<u>Name</u>	<u>Address</u>	<u>Telephone</u>	<u>Single Room</u>	<u>Double Room</u>
Airport Inn-Best Western	Eppley Airfield	348-0222	\$30.00	\$37.00
Best Western-Omaha Inn	4706 South 108th Street	339-7400	\$39.00 - 41.00	\$44.00 - 52.00
Conant/Black Angus	1913 Farnam Street	341-1313	\$15.75 - 20.75	\$18.75 - 25.75
Granada Royale Homotel	7270 Cedar Street	397-5141	\$69.00 \$52.00	\$79.00 (M-th) \$52.00 (F-Sun)
Hill Town Inn	16th & Howard Streets	341-9332	\$23.50	\$28.50 - 40.00
Holiday Inn	3321 South 72nd Street	393-3950	\$38.00 - 45.00	\$43.00 - 57.00
Holiday Inn-Old Mill	655 North 108th Street	496-0850	\$39.00 - 44.00	\$51.00
Howard Johnson's Motor Lodge	3650 South 72nd Street	397-3700	\$38.00 - 41.00	\$44.00 - 49.00
Immanuel Plaza Motel	6901 North 72nd Street	571-6161	\$32.00 - 33.00	\$39.00 - 41.00
Imperial 400	2211 Douglas Street	345-9565	\$21.00	\$24.00 - 26.00
LaQuinta Motor Inn	3330 North 104th Avenue	493-1900	\$30.00	\$34.00 - 36.00
Leisure Inn Motel	4815 "L" Street	733-4000	\$22.95 - 26.95	\$30.95 - 33.95
Marc's Budgetel Inn	10760 "M" Street	592-5200	\$23.95 - 27.95	\$28.95
Motel 6	10708 "M" Street	331-2331	\$15.95 - 19.95	\$22.95
New Tower-Best Western	7764 Dodge Street	393-5500	\$37.00 - 40.00	\$43.00 - 47.00
Oak Creek Inn	2808 South 72nd Street	397-7137	\$33.00	\$38.00
Omaha Marriott	10220 Regency Circle	399-9000	\$57.00 - 67.00	\$69.00 - 79.00
Omaha Travelodge	3902 Dodge Street	558-4000	\$26.00 - 31.00	\$36.00 - 40.00
Paxton Manor	14th & Farnam Streets	346-3330	\$22.00	\$28.00
Ramada Inn-Airport	Abbott Drive & Locust Streets	342-5100	\$41.00 - 42.00	\$48.00 - 49.00
Ramada Inn-Central	7007 Grover Street	397-7030	\$40.00 - 42.00	\$48.00 - 50.00
Red Lion Inn	1616 Dodge Street	346-7600	\$58.00 - 80.00	\$68.00 - 90.00
Regency West-Best Western	909 South 107th Street	397-8000	\$40.00 - 45.00	\$45.00 - 50.00
Rodeway Inn	10909 "M" Street	331-8220	\$37.00	\$44.00
Satellite Motel	6006 "L" Street	733-7373	\$22.00 - 26.00	\$24.00 - 28.00
Shamrock Motel-Best Western	12000 West Dodge Road	498-0400	\$26.00 - 34.00	\$38.00 - 44.00
Sheraton Inn Southwest	4888 South 118th Street	895-1000	\$38.00 - 41.00	\$42.00 - 45.00
Ted's Motel	8423 North 30th Street	453-2600	\$22.00	\$27.00
Thrifty Scot Motel	7101 Grover Street	391-5757	\$26.90 - 32.90	\$31.90 - 41.90
Wayside Inn	7833 Dodge Street	391-7100	\$25.00 - 28.00	\$32.00 - 36.00
Y.M.C.A.	430 South 20th Street	341-1600	\$12.81 - 16.75 \$6.50 (Dorms)	\$18.75 - 19.75

Room Rates as of January 1, 1983 - Rates are subject to change without prior notice by Hotels and Motels.

REGION #1 UPDATE

Spring is just around the corner and when we turn that corner, our cats will once again be on the prowl. Ah, but what is there to do with your cat, just drive around by yourself? Well, that might do for a while, but sooner or later your cat will yearn to be with others of its kind. Now when your cat gets that fever, relax for there is a cure. I have been busy here in Region #1 seeking out places and events where your cat can achieve this happiness. Listed below are the dates and places where your cat can be treated.

July 9, 1983 - Cecil County Dragway, Rising Sun, MD. There will be a Ford only meet sponsored by Performance Ford Club of America, Upper Chesapeake Bay Region. There will be a Ford Car Show and drag racing. The gates will open at 9:00 AM. The cost is \$4.00 for general admission (50% discount to PFCA members). The highlight of the drag racing will be a Super Pro Gas Match Race between a Mustang and a Camaro (see enclosed flyer).

September 18, 1983 - East Cost Mini-Meet, R & J Ford, Lebanon, PA. There will be a Ford only car show sponsored by Lebanon Valley Mustang Association - Penn Central SAAC (Shelby Club). There will be a cougar only class. There will be dash plaques and door prizes. Wooden plaques will be given out to the winners of each class. The more cougars in attendance, the more plaques that will be awarded. Winners are determined by popular vote. The show starts at 9:00 AM. R & J Ford is on Route 422 near Route 72. Pre-registration is \$3.00 and \$5.00 the day of the show. If you wish to pre-register, make your check payable to L.V. Mustang-P.C. SAAC and sent it to Randy Ream, 1817 Janet Avenue, Lebanon, PA 17042. It should be noted with your pre-registration that you learned of this show through the cougar club.

For those of you whose cats are in need of parts:

June 16-19, 1983 - Carlisle PA Summer Carlisle Collector Car Flea Market and Car Corral.

September 29-October 2, 1983 - Carlisle PA Fall Carlisle Collector Flea Market and Car Corral.

Well now that you know how to cure your cat, what's stopping you. Attend these meets. You will find that not only will your cat feel better, so will you. Let's get out and show the world that our cats are alive and doing fine. It's up to you as the membership to support these meets, they have been set up with you in mind and will mean nothing if you do not support them. I will be at all these functions and will be looking forward to meeting with all of you. If you have any questions, please contact me.

Region #1 Director
Randy Goodling

Randy Goodling

Here is a list of some of the events that will be taking place around the Northwest in the coming months. I have broken them down into groups, the first being activities in which Cougars and their owners can participate, and the second group being swap meets. I would also like to mention that our regional club COUGARS NORTHWEST (based locally here in Portland) will be sponsoring many activities that I have not listed, simply because most are still in the planning stages. Anyone interested in joining the club or learning more about it can contact me directly.

ACTIVITIES

May 22	Mt. St, Helens Tour and Picnic Cougar Park, Cougar, WA Sponsored by Cougars Northwest	Info: Laurence Juhnke 11604 S.W. Lancaster Portland, OR 97219
June 5	11th Annual Ford Picnic University of Washington, Seattle, WA By Puget Sound Early V-8 Club	Info: Dean Rayworth 16753 NE 23rd Pl Bellevue, WA 98008
July 17	11th Annual Forest Grove Concours Pacific University, Forest Grove, OR	Info: A.L. Stephens P.O. Box 125 Forest Grove, OR 97116
	3rd Annual Mustang & All Ford Roundup Seattle, WA Sponsored by Mustangs Northwest	Info: Bob Johnson 9036 NE 136 St. Kirkland, WA 98033
Aug 7	Oregon All Ford Picnic Champoeg Park, Champoeg, OR By Mid-Willamette Valley Early V8 Club	Info: Terry Tindle Portland, OR
Nov 4,5,6	6th Annual Northwest Car Collector Show Multnomah County Expo Center, Portland, OR By 30 Portland Area car clubs (NCCA)	Info: Car Show PO Box 251 Portland, OR 97223
June 12	11th Annual Salem Swap Meet Chemeketa Community College Salem, OR	Info: Salem Swap Meet P.O. Box 3031 Salem, OR 97303
July 1,2,3	Reno Swap Meet Sparks-Reno, Nevada	
July 23	9th Annual Vancouver USA Swap Meet Clark County Fair Grounds, Vancouver, WA By Evergreen Old Car Club	Info: Vancouver Swap Meet P.O. Box 2101 Vancouver, WA 98668
Aug 20,21	19th Annual Eugene Swap Meet Eugene Speedway, Eugene, OR	Info: Joe Carpenter 89539 Fir Butte RD Eugene, OR 97402
Sept 10,11	14th Annual Boise Swap Meet and Show New Meridian Race Track, Maridian ID	Info: Ed Javaux 2170 Karen DR Meridian, ID 83642
Sept 18	2nd Annual Banks Swap Meet Banks City Park, Banks, OR By Sunset Ford-Mercury & Cougars Northwest	Info: Greg Kindel P.O. Box 331 Banks, OR 97106



Laurence Juhnke
Laurence Juhnke

"At the Sign of the Cat"

April 17 Sunday, Mustang Birthday Party, Eisenhower Park (near Saffey City), East Meadow, L.I., New York. Popular Vote Trophy and cake. Any questions, please contact F. McIntyre (516) 735-1624 or P. Zito (516) 483-1557.

BE THERE!

Central Illinois Ford Day, Mustang Show and Swap Meet June 5, 1983 at Bob Dennison Ford, U.S. 150 and Veterans Parkway, Bloomington, Ill. 61701. Contact: Mark Wells, 1842 Taft, Norman, Ill 61761 or Charles Knudson, 1220 Sandburg Dr., Bloomington, Ill. 61701.

Michigan, Grandville, May 21, Second Annual Mustang Show and parts swap meet at Grand Village Mall, located 8 miles from downtown Grand Rapids on I-96 Expressway, Exit 69. Sponsored by West Michigan Mustang Club, awards to First and Second places all classes. Dash plaques to all pre-entered cars. Free admission 8 A.M. till 5 P.M. 20' front vendor space, car show or sales lot - \$5.00 advance to May 1 and \$8.00 show day. Additional information Don Campbell (616) 784-5191 days - 4020 West River Rd., Camstock Park, Mi. 49321. Swap Space contact John Baumann (616) 399-9723 - 4211 N. 120th. Ave., Holland, Mi 49423.

POCONO WEEKEND CAR SHOW & SWAP MEET - Shelby's - Mustangs - Cobras - Ford Powered. May 21 & 22 (car show) 1983. At the Quality Inn - East Stroudsburg, PA Rte. 209, Exit #52 of Pa. #80 (1 mile). Registration - \$6.00 - Hot Buffet, \$12.00 - Beer mugs, \$6.00 (Free Beer Sat. & Sun). Rooms \$32.00-single, \$37.00 Db. For add. info. Alec M. Garden, Box 484, Stanhope, N.J. 07874 (SSAE) or (201) 347-8216.

SHELBY AMERICAN AUTOMOBILE CLUB CENTRAL REGIONAL SPRING FLING - May 20, 21, 22, Nashville, In. ---6th Annual Indiana Spring Fling --- Central Regional Meet. The Midwest's major spring Shelby/Ford event, hosted by the Indiana Region, co-sponsored by the IL, Ky, Mi, Mo, and Oh regions of the Shelby American Automobile Club. Parts swap, picnic, car shows, patio barbeque, awards, and autocross for Shelby, Cobra, Tiger, Boss, Mustang, Pantera, and other Ford-powered cars/enthusiasts. Car classes based on early registrations (\$10/ea.) received by May 6. Vendors by pre-registration only. For registration form/information send SASE to: Steve & Joyce Yates, Rt. 1, Box 377, Nashville, In 47448, or call (812) 988-7146.

On Fourth of July weekend 1981, Super Ford Magazine held its First Annual Super Ford Street Machine Nationals in Niagara Falls, N.Y. and that high stepping tourist town hasn't been right since. By Saturday nearly 400 cars had checked into the show area and almost a quarter mile of vendor's space had been filled.

1982 found the Second Annual Super Ford Street Machine Nationals being staged in Dearborn, Michigan, home of Ford Motor Company's World Headquarters.

Albuquerque, New Mexico... May 28-29, 1983 The Mustang Owners Club and Frontier Ford Sales, present the "2nd Annual Southwest Invitational Mustang Meet" to be held in Albuquerque, New Mexico on May 28-29, 1983. Open to all Mustangs, Ford, Shelybys, Cougars, and Special Interest Fords and Mercurys. Activities include: a car show with judging (concours, street, modified, etc.), a swap meet, and other goodies. Further information contact: Paul G. McLaughlin, Mustang Owners Club International, 2829 Cagua Drive NE, Albuq, NM 87110. Or call (505)881-2715, after 5:00 pm.

WISCONSIN; Madison--March 27, 1983. Fourth annual spring all Ford Parts swap, sponsored by N. Woods region SAAC, at East Towne Ford, Hwy 151, 1 mile north of I 90-94. Vendors \$5, Admission \$1. Kerry Page 208/249-2631 days.

June 18, 1983, Mechanicville, N.Y. - THIRD ANNUAL DEALER'S DAY at Jack Byrne's Ford & Mercury Dealership. Trophies awarded for "Best of Class" and "Best of Show". Info: Adirondack Shelby-Mustang Region, Inc., SAAC, P.O. Box 107, Burnt Hills, N.Y. 12027 or call John Barnes at (518) 885-9013 Louis Dahoda at (518) 371-6547.

3rd Annual March of Dimes Car Show to be held inside Jessamine Mall Shopping Center May 27, 28. Classic Fords of all eras cordially invited. Contact Dave McDuffie 930 Trailmore, Sumter, S.C. 29150 803-481-2563.

CARLISLE, PA. APRIL 21-24, 1983. The Flea Marketeers Spring Carlisle Collector Car Flea Market and Corral, Carlisle Fairgrounds. The Flea Marketeers, P.O. Box 1974, Lemoyne, Pa. 17043 PH. 717-761-3440.

July 22, 23, 24, Great Bend, KS - Shelby Owners of America, Inc. National Convention. Shelby, BOSS, & Mustang Show, Drag racing, Autocross, car show and much more. For more information contact Randy Schwartz, R.R.4, Great Bend, Kansas 67530 or call 316-792-6138.

1983

Based at the Hyatt Regency, our second year's event attracted over 700 cars representing all classes from Shelybys, Mustangs, Thunderbirds, Falcons, Panteras, Tigers, Galaxies, Fairlanes, Mercurys, "Factory Lightweights" and AFX's, to Super Stockers, rods, modifieds, V-8 Pintos, Cougars and Griffiths. The vendors lots filled quickly and many of them had to be placed on the lawn surrounding the lots. It was a great show and Ford Motor Company's help and contributions made it even greater.

JUNE18 - Sixth Annual Ohio Regional, Xenia, Ohio. Sponsored by Southern Ohio Region of SAAC. More info. call or write: Bob Frey, 2076 Owendale, Dayton, OH 45439 (513) 298-9477.

JUNE 12, Rose City Rods & Machines 3rd Annual Rod & Custom Car Show at Baker Park, New Castle, Indiana. Lots of trophies and awards. Dash plaques and goodie bags to the first 200 cars. For more info: Call (317) 722-4213 (Bill) or (317) 722-6651 (Dennis) after 5 pm.

5th ANNUAL KNIGHT'S POINT PICNIC: North Hero, VT. Parts swap, Potluck lunch, we have Hibachis available, also swimming. Come for some fun and sun with the cars of Shelby American. The date will be July10, Sunday, with a rain date of July 17, Also a Sunday. Join us, and hope to see you all there!

June 18, 1983, Mechanicville, N.Y. - THIRD ANNUAL DEALER'S DAY at Jack Byrne's Ford & Mercury Dealership. Trophies awarded for "Best of Class" and "Best of Show". Info: Adirondack Shelby-Mustang Region, Inc., SAAC, P.O. Box 107, Burnt Hills, N.Y. 12027 or call John Barnes at (518) 885-9013, Louis Dahoda at (518) 371-6547.

4th ANNUAL GULF COAST MUSTANG ROUND-UP KEY-FORD, PENSACOLA, FL. 19 March 1983. For further information call Vivian McClain, (904) 477-0761.

CARLISLE, PA. SEPT. 29 - OCT. 2, 1983. The Flea Marketeers Fall Carlisle Collector Car Flea Market and Corral, Carlisle Fairgrounds. The Flea Marketeers, P.O. Box 1974, Lemoyne, Pa. 17043 PH. 717-761-3440.

August 14, 1983, Clifton Park, N.Y. - FIRST ANNUAL CLAM STEAM/CAR SHOW at Krause's Halfmoon Beach Grove. One fee covers all you can eat and drink for the day. Info: Adirondack Shelby-Mustang Region, Inc., SAAC, P.O. Box 107, Burnt Hills, N.Y. 12028, or call John Barnes at (518) 885-9013 or Louis Dahoda at (518) 371-6547.

Maryland, North East, July 9-10, 2nd annual "Ford Firecracker Weekend", all Ford & Mercury Car Show, Drag Race, and Swap Meet sponsored by the Upper Chesapeake Bay Region P.F.C.A. at Cecil County Dragway, 195 exit 8, \$4.00 general admission (includes pits) info: Tom Dodge, 2508 Pac Lane, Edgemere, Md.21219 PH: 301/477-8149 or 301/838-2354.

Englishtown, N.J. Swap Meet and Auto Shows April 29-30 - May 1st. Rods, Customs, Vans, Pick-ups, 4 x 4's, Kit Cars, Race Cars, Sat., April 30th, Stock Production to '72 Sun. May 1st. Info. Raceway Park, Pension Rd., Englishtown, N.J. 07726 (201) 446-6331 Days (201) 938-5519 Eves.

This year, if our growing trend continues, we expect to have over 1,000 Super Fords in attendance. We are once again planning our event to be held in Michigan, only this time, through the cooperation of Ford Motor Company, we will be using Ford's Utica Proving Grounds to stage our event. This giant 2½ mile oval track features plenty of room for our show and events, while providing excellent security and free parking. The April issue will have our entry forms and complete details on the event.

So plan on joining us for the Third Annual Super Ford Street Machine Nationals, August 19, 20, 21 in Utica, Michigan.

MAY 1, 1983.....FIRST ANNUAL NORRIS FORD ROADEO & SWAP MEET....
 HAVE A BEST COUGAR CLASS FOR INFO:NORRIS FORD
 C/O FLOYD MILLER, 900 MERRITT BLVD, DUNDALK, MD.
 21221 PH.#301-285-0200

MAY 15,.....DOVER INTERNATIONAL SPEEDWAY, DOVER, DEL.....
 MASON *DIXON 500 race with Speedway Ford-Mrees
 info:SPREEDWAY F*M CLUB, c/o CHICK SCHIESSER JR,
 526 Eastern Blvd, ESSEX, MD. 21221 PH. 301/6879420

MEMORIAL DAY WEEKEND.....COUGAR CLASS INFO...VIC YARBERRY#55,
 ALBUQUERQUE, NM. PH#505-821-1002 after 5PM.

LABOR DAY WEEKEND.....Inter, Mustang Meet, Missoula, Mont. info:
 Den Rasmussen #1237

MAY 29,.....ALL FORD SHOW(COUGAR CLASS)SITE:HISTORIC
 MUSEUM OF TRANSPORT, 3015 BARRETT STATION RD,
 ST. LOUIS, MISSOURI

JULY 9.....CECIL COUNTY DRAGWAY, RISING SUN, MD. I-95 to
 EXIT 8, follow signs to the track, FORD VS
 CHEVY AT 6PM. WEATHER HOTLINE 301-287 6280

JULY 9 & 10.....PERFORMANCE FORD CLUB OF AMERICA THERE
 2ND ANNUAL FORD AND MERCURY CAR SHOW AND DRAG RACE
 FOR INFO 609-8581665 or 301 477 8149 OR SEND
 SASE TO CECIL COUNTY DRAWAY, 718 Hadden Ave,
 Collinswood, N.J. 08108

JUNE 24, 25, 26.....SPRINGFIELD, ILL. CAR CRAFT MAGAZINE NATIONALS,
 ILL. STATE FAIRGROUNDS.

SHELBY AMERICAN NATIONALS***DEARBORN, MI. 4th July weekend.

MAY 14, 15.....10th Annual Seattle Swap meet, MONROE, WA.
 info: Puget Sound V8, POBox 12613, Seattle, WA.

MAY 22.....7th Roseburg Swap, Douglas County Fair-
 grounds, Roseburg, OR. info: Jack Zink, 2050
 Stephens, Roseburg, OR. 97470

June 11, 12.....8th Bremerton Swap..Pierce County Fair-
 grounds, Bremerton, WA. Info: Swap Meet, POBox 685
 Bremerton, WA. 98311

1967 CAR OF THE YEAR

If you are interested in the 1967 thru 1973 Mercury Cougar there is an automobile club on the West Coast dedicated to these early Cats.



**COUGARS
NORTHWEST**

Cougars Northwest is an incorporated non-profit club made up of Cougar enthusiasts, whose objective is the preservation and enjoyment of these classic vehicles.

Our monthly newsletter, "Sound of the Cat", informs our members through a mutual exchange of information about common problem areas, reproduction parts, hard to locate parts and restoration guidelines.

Club sponsored events include cruises, rallies, car shows and a swap meet. Monthly membership meetings are held for those members able to attend.

For additional information and a copy of our newsletter, please contact a representative in your area.

Cougars Northwest, Inc.
1964 N.W. Pettygrove
Portland, OR. 97209

Cougars Northwest
% Danny Warren
18708 Second Dr. SE.
Bothell, WA. 98011

Cougars Northwest
% Kevin Marti
3507 W. Krall St.
Phoenix, AZ. 85019

Cougars Northwest
% Vergil Brown
1613 Lincoln Dr.
St. Charles, MO. 63301

Cougars Northwest
% Jim Chambers
733 Cook
Billings, MT. 59101

GT XR-7 GT-E XR-7 "G" ELIMINATOR

GT XR-7 GT-E XR-7 "G" ELIMINATOR

DAN GURNEY SPECIAL

F1 If Cover Check At Point H Not OK

With vacuum still applied at point H, remove the hose at point L. The covers should open.

If Cover Check At Point L Not OK

Repair or replace the tee in the open (green) circuit.

If Cover Check At Point L OK

Apply vacuum to the connector at K. Turn the headlight switch off. The covers should close.

If Cover Check at Connector K Not OK

Repair or replace the tee in closed (yellow) circuit.

If Cover Check At Connector K OK

Manually raise the covers and apply vacuum to the hose at point G. The headlight covers should close.

If Cover Check At Point G Not OK

Repair or replace the hose between points G and K.

If Cover Check At Point G OK

Replace or repair the headlight switch.

F2 If Cover Check At Point H OK

Manually close the headlight covers. Apply vacuum to the hose at point F. The headlight covers should go up.

If Cover Check At Point F Not OK

Repair or replace the hose between points F and H.

If Cover Check At Point F OK

Check for vacuum at the hose at point E.

If Vacuum Check At Point E Not OK

Repair or replace the hose between points D and E.

If Vacuum Check At Point E OK

Replace the headlight switch.

VEHICLES WITH INTERNAL SPRINGS IN HEADLIGHT COVER MOTORS

HEADLIGHT COVERS REMAIN CLOSED ALL OF THE TIME

Verify the complaint. Turn the headlight switch ON and remove the green hose from either cover motor. The headlight covers should open.

A1 If Headlight Cover Check Not OK

Check the yellow hoses and connectors in the close circuit for plugged hoses or kinks.

If Yellow Hose Check Not OK

Repair the yellow hose as required.

If Yellow Hose Check OK

Check the mechanical operation of the headlight switch.

If Headlight Switch Operation Not OK

Replace the headlight switch.

If Headlight Switch Operation OK

Check the vent holes on the headlight switch and unplug the holes as required.

A2 If Headlight Cover Check OK

Check the green hoses and connectors in the open circuit for plugged hoses or kinks.

If Green Hose Check Not OK

Repair the green hose as required.

If Green Hose Check OK

Check the mechanical operation of the headlight switch.

If Headlight Switch Operation Not OK

Replace the headlight switch.

If Headlight Switch Operation OK

Check the vent holes on the headlight switch and unplug the holes as required.

ONE HEADLIGHT COVER REMAINS CLOSED ALL OF THE TIME

Verify the complaint. Turn the headlight switch ON and remove the green hose from the inoperative motor. The headlight cover should open.

A1 If Cover Check Not OK

Remove the yellow hose from the cover motor. The headlight cover should open.

If Yellow Hose Check Not OK

Check for interference of the cover mechanism.

If Cover Interference Check Not OK

Repair or replace the components where interference is taking place.

If Cover Interference Check OK

Replace the affected headlight cover motor.

If Yellow Hose Check OK

Check the yellow hose between the cover motor and the tee in the close circuit for plugged conditions or kinks.

If Yellow Hose Plugged Check Not OK

Repair or replace the yellow hose as required.

If Yellow Hose Plugged Check OK

Repair or replace the tee in the closed circuit.

A2 If Cover Check OK

Check the green hose between the tee and the cover motor in the open circuit for plugs or kinks.

If Green Hose Check Not OK

Repair or replace the green hose as required.

If Green Hose Check OK

Repair or replace the tee in the open circuit as required.

HEADLIGHT COVERS REMAIN OPEN ALL OF THE TIME

Verify the complaint. Start the engine and turn the headlight switch ON. Perform a leak test on the hose

A1 If Leak Test At Point D Not OK

Turn off the headlight switch and perform the leak test at point D again (Fig. 6).

B1 If Second Leak Test At Point D Not OK

Perform a leak test on the headlight cover motors.

If Cover Motors Leak Test Not OK

Replace the inoperative headlight cover motor.

If Cover Motors Leak Test OK

Check for vacuum through the white hose at the headlight switch.

If White Hose Vacuum Check Not OK

Repair or replace the hose between the check valve and the headlight switch.

If White Hose Vacuum Check OK

Perform a leak test on the headlight switch.

If Headlight Switch Leak Test Not OK

Replace the headlight switch.

If Headlight Switch Leak Test OK

Repair leaks in the open and close circuits.

B2 If Second Leak Test At Point D OK

Check the cover motors, green hoses and connectors in the open circuit for leaks.

If Open Circuit Check Not OK

Repair or replace the leaking component.

If Open Circuit Check OK

Replace the headlight switch.

A2 If Leak Test At Point D OK

Turn off the headlight switch and perform the leak test at point D again.

B3 If Second Leak Test At Point D Not OK

Check the cover motors, yellow

If Close Circuit Check Not OK

Repair or replace the leaking component.

If Close Circuit Check OK

Replace the leaking headlight switch.

If Second Leak Test At Point D OK

Check for vacuum at connector D.

C1 If Vacuum At Connector D Not OK

Cap connector B and recheck for vacuum at connector D.

D1 If Recheck at Connector D Not OK

Check for vacuum through the hose at point C.

If Hose Vacuum Check At Point C Not OK

Repair or replace the hose between the manifold and the check valve.

If Hose Vacuum Check At Point C OK

Replace the check valve.

D2 If Recheck At Connector D OK

Perform a leak test on the vacuum reservoir.

If Reservoir Leak Test Not OK

Replace the vacuum reservoir.

If Reservoir Leak Test OK

Repair or replace the hose between the check valve and the reservoir.

C2 If Vacuum Check At Connector D OK

Check for vacuum through the yellow hose to the cover motors at the tee.

E1 If Yellow Hose Vacuum To Cover Motors Not OK

Check the vacuum through the white hose to the headlight switch.

If White Hose Vacuum To Headlight Switch Not OK

Repair or replace the hose between the headlight switch and the check valve.

If White Hose Vacuum to Headlight Switch OK

Check for vacuum at the yellow connector on the headlight switch.

If Headlight Switch Yellow Connector Vacuum Not OK

Replace the headlight switch.

If Headlight Switch Yellow Connector Vacuum OK

Repair or replace the plugged close circuit.

E2 If Yellow Hose Vacuum To Cover Motors OK

Turn the headlight switch ON and check for vacuum through the green hose to the cover motors.

If The Green Hose Vacuum OK

Repair the plugged venting holes in the headlight switch.

If The Green Hose Vacuum Not OK

Check for vacuum at the green connector at the headlight switch.

If Headlight Switch Green Connector Vacuum Not OK

Replace the headlight switch.

If Headlight Switch Green Connector Vacuum OK

Repair or replace the plugged open circuit.

HEADLIGHT COVERS OPEN AFTER THE ENGINE IS TURNED OFF BUT WORK PROPERLY WHEN THE ENGINE IS RUNNING

Verify the complaint. Perform a leak test on the hose at point B.

If Leak Test At Point B Not OK

Perform a leak test on the vacuum reservoir.

If Reservoir Leak Test Not OK

Replace the vacuum reservoir.

If Reservoir Leak Test OK

Repair or replace the hose between the check valve and vacuum reservoir.

If Leak Test At Point B OK

Remove the hose from the connector C and perform a leak test at connector D on the check valve.

If Leak Test At Connector D Not OK

Replace the check valve.

If Leak Test At Connector D OK

Use the diagnosis procedures outlined for Headlight Covers Remain Open All Of The Time.

HEADLIGHT COVER VACUUM SYSTEM LEAK TEST

A leak test on any part or component of the headlight cover vacuum system, can be accomplished with the use of the vacuum test probe. Refer to Vacuum Test Probe for fabrication. To perform the leak test, plug the probe into the system at the desired point. The reading on the gauge should momentarily fall below the pre-set value of 14 inches of vacuum. If there are no leaks in that part of the system being checked, the gauge reading should

come back to 14 inches of vacuum and hold steady. If a leak is present in the system, the gauge reading will not come up to 14 inches of vacuum.

The leak test for the headlight switch can be accomplished by attaching the vacuum test probe to the center (white) port of the headlight switch and capping the two outside ports. Move the switch selector thru the OFF-PARK-ON position and observe the reading on the vacuum probe gauge. The gauge should read 14 inches of vacuum in all of the positions. If the reading should fall off at any of the positions, the headlight switch should be replaced.

VACUUM TEST PROBE

A vacuum gauge is required to diagnose and test a vacuum control system. The Rotunda Fuel Pump Tester Gauge (ARE345) is recommended. It is also recommended that the vacuum gauge be used, as a part of a vacuum probe tester. Ordinarily, a vacuum gauge is used alone to measure the vacuum from a vacuum system hose or nipple, reservoir, or the engine intake manifold. A vacuum probe tester, on the other hand, is used to supply a definite amount of vacuum to a particular point in the system. It tests the system from this point to a component.

A vacuum probe tester is not commercially supplied, but it is easily made.

1. Cut or splice a length of 3/16-inch hose long enough to reach from the engine intake manifold to the most remote component in the vacuum system. Call the ends of the hose the manifold end and the working end.
2. Insert a 4-way connector into the working end of the hose.
3. Attach a vacuum gauge to one of the 4-way connector nipples (Fig. 7).
4. Install a short length of 3/16 hose with an adjustable hose restrictor

on another nipple of the 4-way connectors.

5. Install a short length of hose on the last nipple of the 4-way connector. Insert a Tee connector into this hose.

6. Install a short length of hose

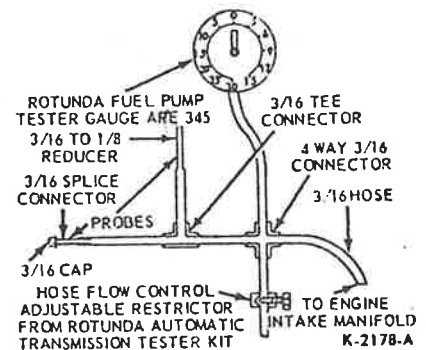

FIG. 7—Vacuum Test Probe

to the two open ends of the Tee connector (Fig. 7). Install a 3/16 - 1/8 reducer in one hose and a 3/16 splice connector in the other hose. By adding or removing connectors (splices) to these test probe hoses, they can be connected to any 3/16-1/8 hose, nipple, or connector, while the other test hose is plugged, or both the 3/16 and 1/8 tester probes can be used at the same time.

To adjust the probe to the required 14 inches of test vacuum, plug the test probe hoses into the vacuum source at the carburetor, and adjust the hose restrictor until the vacuum gauge reads 14 inches. The vacuum supply at the end of the test probe hoses should be checked often, as the engine warms up, loads up, etc.

"D.C." Cougs

Lee Harrison #699

Good news abounds for members in the Capital area. Following a picnic in the fall of 1982 and much winter discussion and planning, the National Capital Area Cougar Club is a reality. At this point no officers have been elected nor meetings held, but club applications have been mailed to all local CCA members along with a draft set of Club by-laws.

As of the first of March twelve applications for membership have been received. We are optimistic about our club because of the enthusiasm displayed at last year's picnic. For their patience and support I thank those Cat lovers who have joined the NCACC.

These members are (in the order we received applications):

Lee and Frances Harrison #699
Jim and Pat Sansburg #1260
Mike and Sylvia Dewald #1498
Barry and Mary Brown #891
Kathy Hartman #783
Craig Wunderlich #1308
Sara Ann Richey #1380
Perry Lewis
Abe and Rosemary Kooiman #1313
Greg Howarth #1494
Mike and Myrtle Moltz #1550
Carl Hecox #1261

One of our members, Carl Hecox, entered his super 1969 XR-7 Eliminator in the recent World of Wheels show held in the new Washington, D.C. Convention Centre. Carl's exhibit is pictured at the right. Carl has also contributed ideas on a logo for the NCACC.



In addition to the local club we have been invited to attend the annual Southern Maryland Antique Auto Club flea market and auto show as a group. Anyone who would like to attend please contact me

at (301)-283-5446 or send a self-addressed stamped envelope so we can provide details when received. The show's only restriction is that the cutoff is the 1970 model year. There are always a lot of Mustangs, so come on Coug owners, let's show them what class is all about!! Plan to attend!! We must send in our list of participants early, so contact me as soon as possible. All who attend will receive a plaque if we register as a group. The show is scheduled for July 16, 1983.

If there are any Capital area members we failed to reach about the new local club I apologize -- it was not on purpose. Please send a SASE to me, Lee Harrison, at Box 407, Bryans Road, Md., 20616, and we'll happily send on an application!!

* * *

ATTENTION CAT OWNERS!!!

John of Cougar Central, 0-4211 North 120th Ave., Holland, Michigan, 49423, needs our help. He needs to beg, borrow, or buy a '69-70 Eliminator rear spoiler to use as a prototype so that he will be able to reproduce these. He could also use a front one. HELP?!!

* * *



Dan Gurney Cougar.
Limited edition.
Specially priced.

With deluxe interior, remote control mirror, wide tread whitewalls, Gurney decal, special turbine wheel covers, plus concealed headlamps, buckets, 302 V-8 engine, sequential rear turn signals, etc. And remember we said specially priced.



The Fine Car Touch
inspired by the Continental.

MERCURY



MEET SUPER CAT

By John Paradise



© 1982 PARADISE

Way back in 1968, after having gone through a couple of used cars, I made the decision to spring for a brand new car. After scanning all the available models that Ford and Mercury had to offer, I made a decision, I ordered a Cougar. It was an excellent car, medium-blue metallic with a white vinyl top, black XR-7 leather interior, 390 GT engine and suspension, automatic, AM/tape, tilt wheel, the works!

I really loved that car, and soon after the purchase, I began making some performance modifications. Within the first week the smog pump and lines found their way to the trash. Next, an aluminum Edelbrock four barrel manifold and a 780 CFM Holley was installed along with a set of tubular headers. The annoying bog that accompanied the increased carburation forced me to tap into the engine and make a cam change. I didn't go for anything wild, just a nice Crower

hydraulic stick with anti pump-up lifters which I complimented with a set of 427 pushrods and adjustable rockerarms. To improve transmission performance, I installed a full manual valve body, and quickness was improved by swapping the 3.50 open rearend for a 4.30 Detroit locker.

You would have had to be there to see the faces on the mechanics and salesmen when my muscular Cougar snorted and snarled as it rumbled into our mild mannered Lincoln-Mercury dealership for it's 6,000 mile check-up. While still in awe from the transformation of the elegant XR-7 into a muscular supercar, which I felt better represented it's namesake, the owner of the dealership summoned up enough strength to go to his file and pull my warranty papers out and rip them into little pieces, tossing them like confetti into the air right in front of me. It was great.

Cars have come and cars have gone, but I've always had a soft spot in my heart for the Cougars. In the pony car group that the Cougar competed in from 1967-1973, the Cougar was the obvious underdog, (no pun intended). The high standard of quality that the Lincoln-Mercury Division endowed upon the Cougar added to it's luxury image, but it also added to it's price tag as well as it's weight. In 1967, the year of the Cougar's introduction, the Cougar was the most expensive and heaviest production pony car. When it came to performance options, Cougar once again trailed the pony car crowd, while it's blood relative, the Mustang, led the field.

Now the muscle and pony cars of the 60's and early 70's have become collector's items and once again the Cougar finds itself trying to claw out an existence. If you own a Mustang, I'd venture to guess that 95% of the parts you'd need to restore your car are either still available from Ford or through aftermarket sources. Cougar owners are not so fortunate. To date I am not aware of any dealers or shops dealing strictly in Cougars, and the list of pieces still available from Lincoln-Mercury is nearly non-existent.

Because of this imbalance in parts availability, and my own fondness for Cougars, a decision has been made to start a business with an emphasis on reproducing obsolete 1967-73 Cougar parts. This is no spur of the moment decision, it is the result of several months of careful planning. The name of the new business is Super Cat, a subsidiary of Super Ford. Check out our ads in **SUPER FORD MAGAZINE.**

SEE INSIDE BACK COVER FOR MORE INFO.



#1605, Don Lane, Ontario



#1619, Mark Hamel, Pa.



#1578, Jack Finney, Calif.

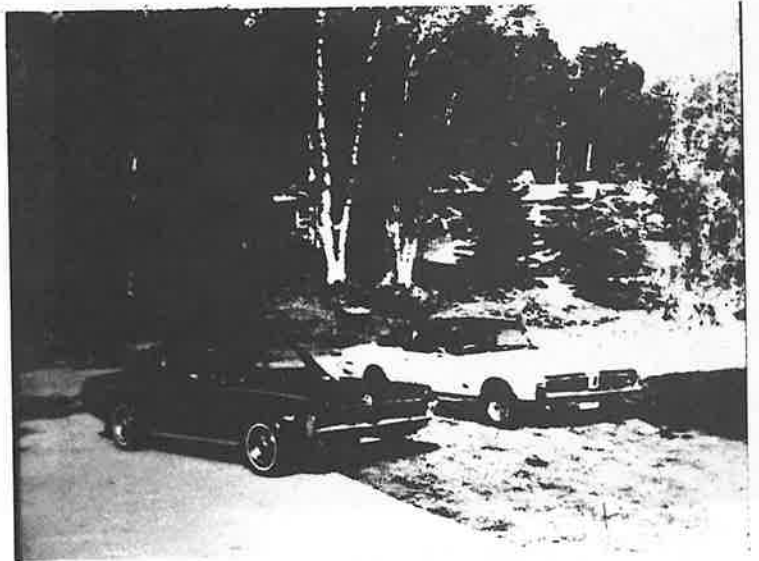

#798, Dan Keough, Mich., Calif.



#1590, James John, Calif.



#1575, Mark Tutalo, Ariz.



#1416, Larry Kelly, Fla.



#1014, Chris Sivak, Ill.



#1584, Ford Wiggins, N.Y.



#1476, Ron & Jean Henry, Calif.



#1552, Tom Leighty Jr., Ohio



#743, Tim Hurst

COUGAR CLASSIFIEDS

- Wanted; '67 Cougar NOS or mint used 1 pr.door sill gaurds PT.# 6513242, 4 in 1 Rallye gauge#10 B944, Radiator screen#8198, Tool Kit#17003, '68 Red plastic centers for wire wheels, & '68 access.&optional equip.booklet:Bill Saunders, 7215 Wheatland Rd, N.Salem, OR. 97303
- Wanted: '67-8 Cougar XR-7, must be SUPER CLEAN AND ORIGINAL, must have air cond.:Martin Roenigk, 26 Barton Hill, East Hampton, CT. 06424 or PH# 203-267-8682
- For Sale: '67-8 Electronic replacement turn signal sequencers \$40, NOS '67 GT letters \$10 pr, front valence panel \$55, 3spd & 4 spd back up switch \$15 ea, Wheel well mouldings \$15 ea, USED: parting out '68 XR-7 GT, '67 Std r/door \$50, Trunk \$34, Tan XR-7 interior, taillights \$15 ea, rear valence \$20, COUGAR front floor mats blk \$30pr, R/headlight grille \$40, '67r/rear emblems \$15 pr, '68 rear reflectors \$5.ea, Many more small parts. WANTED: 1 or more pairs of '68 GT letters PT#C8WB16DO42 A & B, also on '71 GT cars: Vic Yarberry, 7105 Winans Dr. N.E, Albuquerque, NM, 87109 PH#505 821 1002 after 5PM MST
- For Sale: '68 XR-7, 88,000 original miles, forest green, 2nd owner, CA. car, PS, AIR, auto: Bill Aseltine, Rancho Palos Verdes, CA. 5811 Ironwood, Palos Verdes, CA. PH#213-378 5912
- INFORMATION WANTED: On the whereabouts of my 1st Cougar a 1969 Conv. plane jane, Lt. Ivy yellow, tilt, PW, conering lights, VIN#9F92H532590: Mike Arken, 2970 Rustic Dr, San Jose, CA. 95124
- Wanted: '70 XR-7 convertible, 351C 4V, 4 spd, restorable: R.Martin, 1720 Lehigh, Boulder, CO. 80303
- For Sale: 1969 Interiors: Blue 2B from convertible, red 2D, aqua 2K Jim Rakowsky, 18660 River Cliff Dr, Fairview Pk, OH. 44126 PH# 216 356 1291
- Wanted: Factory AM/FM radio, uncut faceplate blk, and trim bars for '69 Cougar. Also chrome trim pieces for f/left fender, extension, std blk arm rests for '69 Eliminator: Tres Wright, 10170 Beekman Pl, Houston, TX. 77084
- Wanted: '68 GTE(427) or XR-7G(390 w/sunroof). Prefer 4 spd, Write: Barry Oland, 5337 Cypress St, VanCouver, B.C. Canada V6M 3R3 Ph.#604 261 3504
- Wanted: '68 XR-7-d/s armrest blk, ashtry for rear of console, door handle strap pass side w/retaining clip: Bill Hansel, 1234 W. Delores St, Wilmington, CA. 90744
- Wanted: Front spoiler for '70 Eliminator: Dan Pothast, RR 1, Box 73 Melbourne, IA. 50162
- Wanted; Trailer hitch for '68 Cougar: Merle Smith, 496 Panoramic Hwy, Mill Valley, CA. 94944
- Wanted: Horn ring '67-8 PT#C8AA13A800B, radio face plate w/metal door for console on 67-8: K. Van Zwiene, 63 Elm Ave, Rumford, RI. 02916

COUGAR CLASSIFIEDS

- For Sale:** '67 Cougar complete front end perfect, off car since mid 1968 \$650. R & L Doors w/mirror \$400, Tailights not pitted \$100. Trunk \$75. Write: Speedway Fords Auto Club, c/o Chick Schiesser Jr, 526 Eastern Blvd, Baltimore, MD. 21221
- For Sale:** Many '69-70 Cougar parts write or call your needs. tilt wheel '70 \$100, Dash pads \$60, Write: Tom Jacobellis c/o CCA or ph#212-892-3849
- WANTED:** FACTORY PHOTOS, MAGAZINE ADS, ROAD TESTS ANYTHING PERTAINING TO COUGARS, MODELS (PLASTIC & METAL) FOR NEWSLETTER ALSO WANT TO PUT TOGETHER ANOTHER CALENDAR LIKE LAST ONE. SEND TO: Tom Jacobellis c/o CCA.
- Wanted:** Deluxe spinner hubcaps for '67-8 (not wires), rubber parts for top assembly on '69-70 Convertible, :H. Sullivan, 522-66th Ave, Fridley, MN. 55432
- For Sale:** COUGAR OWNERS MANUALS '68 thru '74 \$8.50 ea, Shop Manuals 67/8 \$33. ea, '69 \$41.50, '70-74 \$30 ea, Wiring Diagrams '69-74 \$7.50 per year, ALL ORIGINAL FORD, WE PAY SHIPPING: BOB COOK FORD, Hazel, KY. 42049 Member #1107
- Wanted:** '67 Cougar NOS chrome R & L side for hood, LH "COUGAR" name plate, window weathersrip R & L doors: Scott Plowman, 736 Franklin S., Hutchinson, MN. 55350 PH# 612-587 4750
- For Sale:** STOP SPENDING BIG BUCKS to make your Cougar handle, KYB Gas Shocks \$25.00 ea. Sway Bar Kits also available Auto Forum East, PO Box 221, Statuon A, Flushing, N.Y. 11358
- For Sale:** '67/8 AM/FM factory radio exc. cond, trade for tilt wheel for '69 XR-7 or \$50 : Paul Modestino, 813 Broad St, East Weymouth, MA. 02189 PH# 617-335 8200
- Wanted:** Trunk key lid emblem for '68 XR-7G, any cost, also information on XR-7Gs, will pay: Greg Hoerter, 5311 N 55th St, Milwaukee, Wisc. 53218 Ph# 414 464 0483
- For Sale:** 1969 XR-7 convertible, console, 4 channel stereo, PS, tinted glass, radials, auto, dual exh, complete 8yr histry, car is bodily perfect, needs only drivers floor pan \$3,600 FIRM: Ben Leone, 41 St. Mathis St, Bridgeport, CT. PH#203-384 1935

CLASSIFIED AD RATES ARE AS FOLLOWS: Members \$1.00 for 30 word ad, Non members is 20¢ per word. If you have a Business and wish to place a business card ad get in touch with Tom Jacobellis at CCA for rates. ALL CLASSIFIED ADS ARE SENT TO THE EDITOR MIKE BERRY: REMEMBER DEADLINE

CAR SHOW: July 16, Weymouth Rotary Club is sponsoring a Antique and Classic Car Show at the Weymouth Naval Air Station in Mass. For info: Paul Modestino PH#617-335-8200

COUGAR CLASSIFIEDS

WANTED

Pictures of 1967 - 73 Cougars

SUPER FORD MAGAZINE is in the final stages of completing a book on Cougars, and we are currently looking for black and white photographs and color slides of stock, original Cougars to illustrate our book. If interested in contributing pictures, drop us a line and we'll send you a special "run down" sheet on the type of pictures we're looking for.

Send to: Cougar Photos
c/o Super Ford Magazine
188 Ovid St.
Seneca Falls, N.Y. 13148

WANTED: '69-'70 lower front spoiler to be used as a pattern for reproducing the spoiler. Can be cracked or broken, but must all be there. Also, rear spoiler for '69-'70. JOHN'S COUGAR CENTRAL, 0-4211 N. 120th Ave., Holland, MI. 49423. 616-399-9723 evenings.

FOR SALE: Reproduction fiberglass parts: '68 GT-E & XR-7 Hood Scoops, \$49.95. '69-'70 Eliminator Hood Scoops, \$49.95. Metal reproduction parts: Rear Inner Quarter Repair Panels, '67-'68, \$22.00 each. '69-'70 \$23.00 each. State left or right! JOHN'S COUGAR CENTRAL, 0-4211 N. 120th Ave., Holland, MI. 49423 616-399-9723 evenings.

FOR SALE: Reproduction COUGAR parts. Black Shifter Slide for '67-'68 center console, \$2.50 each. Aluminum Shifter Plate (goes around shifter dial), \$5.00 each. '68 XR-7 & Deluxe Arm Rest Plugs (paint to match), \$3.00 each. JOHN'S COUGAR CENTRAL, 0-4211 N. 120th Ave., Holland, MI. 49423, 616-399-9723 evenings.

FOR SALE: COUGAR CATALOG. Send \$1.00 for current catalog. Now working on trunk mats and metal repair panels. Send me your needs! Add 10% shipping on all items ordered from JOHN'S COUGAR CENTRAL, 0-4211 N. 120th Ave., Holland, MI. 49423 616-399-9723 evenings.

FOR SALE: Used COUGAR parts, good set of '67 front seats, blue, no cracks or tears, \$100.00 for set. 1--dark red over-head console, complete, \$40.00. 1--'69 tilt steering column complete with wiring harness, \$125.00. JOHN'S COUGAR CENTRAL, 0-4211 N. 120th Ave., Holland, MI. 49423 616-399-9723 evenings.

FOR SALE: Mem.#699 parting out 67 & 68 6.5 litre, 68 Plain Jane, 70 plain jane, 68 XR-7. Lee Harrison, Box 407, Bryans Rd, MD.
SASE FOR NEEDS Phone # 301-283 5446.

WANTED: Chris Halla (Past Editor of Car Exchange) 445 W. Hill St, Spring Green, WI. 53588 is doing a BOOK on '67 to '74 COUGARS. NEEDS ANY HELP FROM MEMBERS WITH PHOTOS, INFORMATION, articles, ads anything that would be helpful in making this a worthwhile book get in touch with him, BEFORE MID MAY.

COUGAR CLASSIFIEDS

SPECIALTY PARTS
 We Carry A Large Stock Of Falcon, F-100, Mustang, T-Bird, Cougar and Pantera Parts
THE BOSS IS BACK
 Boss 302/351 Aluminum heads . . . ea. bare \$623.20
 (Note modify for Boss 302)
 Boss 351 racing blocks 4-bolt main cap . . . ea. \$956.00
 Boss 302 racing blocks 4-bolt main cap . . . ea. \$956.00
 Boss 302/351 rods . . . ea. \$91.00
 Buy set of 8 only . . . set \$546.00
 Motorsports Performance Catalog . . . \$2.00
 Ask for Gary Moore or Jim Ray
 US 1-800-528-6765 AZ 1-800-352-6315
 1-802-842-8662
DON SANDERSON FORD SPECIALTY PARTS
 5300 Grand Ave., Glendale, AZ 85301
 Prices Subject To Change

QUALITY PLASTIC METALIZING
 • SILVER • GOLD • BRASS
 • SEND SASE • LXWXH OF PART FOR ESTIMATES
 • '67 & '68 MUSTANG DASH PANELS IN STOCK
HERB PLASSMANN Mem. # 455
 346 CENTER BRYAN, OHIO 43506

COUGAR OWNER

For The Largest Stock of 67-73 Cougar Parts in Canada Come See Us

Our Large Inventory Includes:

- FENDERS
- QUARTERS-FLOOR PANS, CHROME
- WEATHERSTRIP, CARPETS
- TRIM & MECHANICAL PARTS
- SALES LITERATURE
- SHOP & OWNERS MANUALS

(Rust Free) Cars Bought For Resale

Rusty Cars Bought For Parts

PRESENT THIS CARD ON YOUR FIRST VISIT FOR A **"FREE GIFT"**

SPECIAL INTEREST CARS

451 WOODY ROAD
 OAKVILLE ONT.
 L6K 2Y2

RAY NADEAU 416-844-8063
 AFTER HOURS 416-844-9707

John's Mustang & Cougar Central

JOHN W. BAUMANN
 0-4211 N. 120TH AVE.
 HOLLAND, MICHIGAN 49423
 (616) 399-9723 (AFTER 6:00 pm)

SPECIALIZING IN NEW & USED
 67-'73 COUGAR & '64½-'73 MUSTANG PARTS

CLOSED SUNDAYS

PONY CAR SPECIALISTS, INC.



P.O. BOX 1264
 CONYERS, GA. 30207
 (404) 483-3528

DEDICATED TO THE AUTHENTIC RESTORATION OF MUSTANGS, COUGARS, CAMAROS, FIREBIRDS AND ALL OTHER SPECIAL INTEREST CARS.

CALL FOR FREE ESTIMATE ON FULL OR PARTIAL RESTORATIONS.

SUPER CAT



Your 'Cougar Connection' specializing in 1967-73 Cougars BUY - SELL - TRADE NDS or Hard to Find Cougar Parts **SUPER FORD Department Super Cat** 188 Ovid St. Seneca Falls, NY 13148 (315) 568-2011

COUGAR HEADLINERS - Made just like original Most colors, 67-68 \$27.75
TRUNK MATS - Authentic reproduction plaid trunk material 67-69 \$15.95
SPARE TIRE COVERS - Made to match trunk mats \$9.50
CARPET KITS - Made just like original A quality molded carpet available in all colors \$100.00
 Please include 10% shipping. Overpayment of shipping will be refunded.
 California residents include 6½% sales tax.

C.J.'s Discount
 7131 Owensmouth Ave., Unit #88 D
 Canoga Park, California 91303
 (213) 349-5251

AT THE SIGN OF THE CAT

PUBLISHED BY THE COUGAR CLUB OF AMERICA
1526 Ericson Place, Bronx, New York 10461
Copyright by Thomas Jacobellis, 1983

* * * * *

PRESIDENT

Tom Jacobellis
c/o C.C.A.
(212)892-3849
Club Items.
Information.

EDITOR "THE CAT"

Mike Berry
2141 Canterbury Dr,
Burlington, Ont. Can.
L7P 1N7
Articles, Photos, Ads.
(416) 637-8154

TECHNICAL ADVISOR-CO-EDITOR

Richard Martin
1720 Lehigh St.
Boulder, CO. 80303
Technical Information,
Q&A "CAT TRACKS"
(303) 499-4012

NATIONAL DIRECTOR

Rod LaBahn
610 Third Ave.
LeMars, IA. 51031
Regional Info.
(712) 546-4214

ELIMINATOR REGISTRAR

Kirk Youngberg
3708 2nd Ave. SW,
Cedar Rapids, IA.
Elim. Registration,
Ques. & Information.

MEMBERSHIP DIRECTOR-HISTORIAN

Jim Rakowsky
18660 River Cliff Dr.
Fairview Pk, OH. 44126
Members dues (new & renewal)
Auto information, Research.
(216) 356-1291

* * * * *

Region #1

Randy Goodling
RD 5, Box 763,
Elizabethtown, PA.
ME, NH, VT, CT, RI, NY,
PA, NJ, MD, DE, VA, NC,
OH, Wash. DC.

Region #2

Harry Hodson Apt. 217A
1800 Ontarioville Rd.
Hanover Pk, Ill. 60103
MI, IN, IL, WI, MN, IA, MO,
KS, NE, ND, SD.

Region #3

Don Rasmussen
6145 Mullan Rd. #7
Missoula, MT. 59802
MT, WY, UT, CO, Idaho

Region #4

Laurence Juhnke
11604 SW Lancaster,
Portland, OR. 97219
WA, OR.

Region #5

Jim Dresbach
3961 Olga Dr,
San Jose, CA. 95117
CA, Nevada

Region #6

Kevin Marti
3507 W. Krall St,
Phoenix, AZ. 85019
AZ, NM.

Region #7

Tres Wright
10170 Beekman Pl,
Houston, TX. 77043
Texas, Okla.

Region #8

Steve Shore
RR #6 Box 699,
Tallahassee, FL. 32304
FL, GA, SC, TN, KY, AL,
LA, Ark, Miss.

Overseas:

Barrie S. Dixon
11 Dean Close,
Partington,
Manchester, England M31 4DJ

* * * * *

CLUB ITEMS FOR SALE.... T-shirts \$8.00 ea, LT or DK Blue specify color and sz.
Decals \$2.00 ea, Patches \$3.00 ea, Pens 50¢ ea, all PPD.

MEMBERSHIP DUES... \$15. US resident, \$20 Foreign/Canada US Funds only,
Membership runs from Jan to Dec each year.

NEWSLETTER..... Published Quarterly (JAN-APR-JUL-OCT), Copy deadline is 1st
day of month before publication. Back issues available
while supply last at \$2 ea ppd.

* * * * *

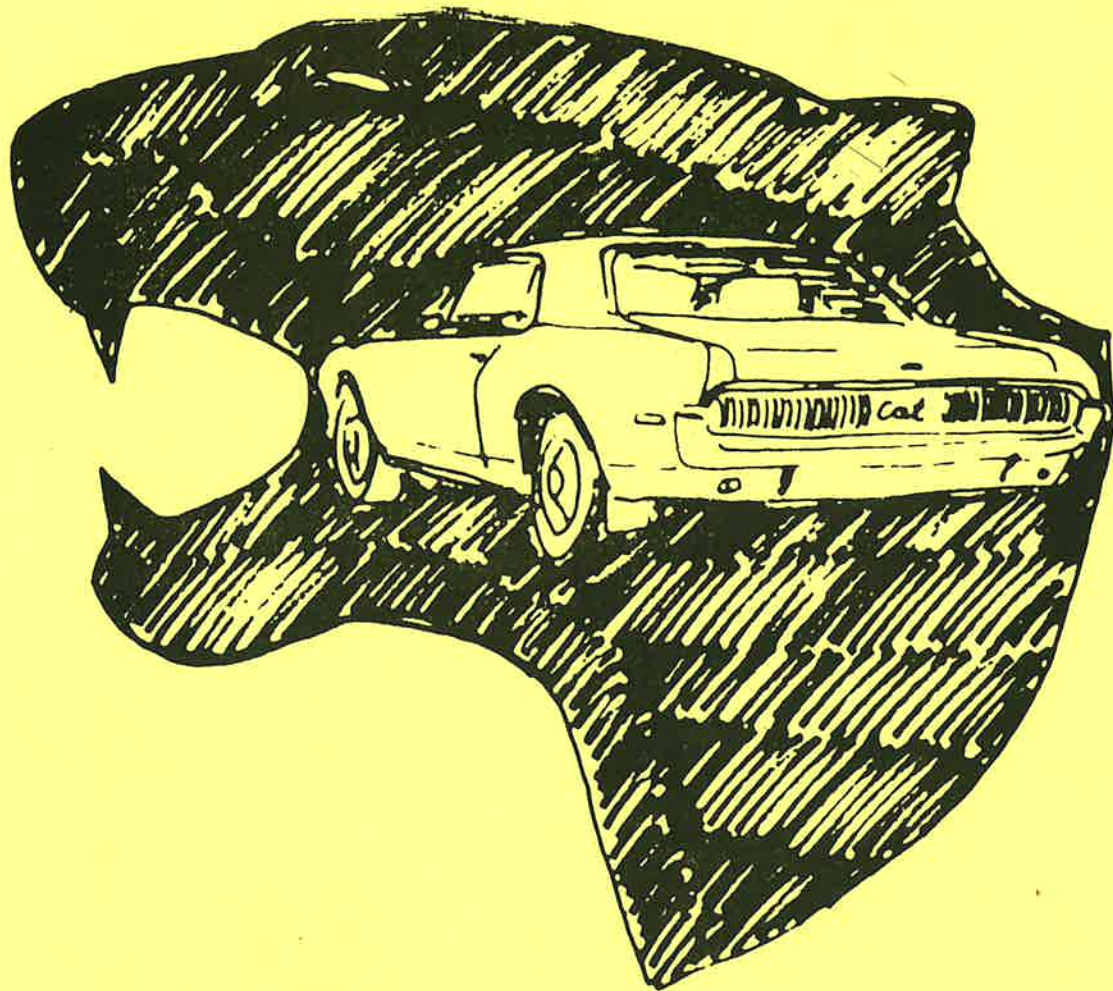

Cougar Club of America
Newsletter Mailer
1526 Ericson Place
Bronx, N.Y. 10461

Forwarding - Return Postage Guaranteed

BULK RATE
U. S. Postage
PAID
Bronx, N.Y. 10461
Permit No. 130



"At the Sign of the Cal"

Mercury
Cougar