

June-July, 81

AT THE SIGN OF THE CAT
A publication of the Cougar Club of America
1526 Ericson Place, Bronx, New York 10461
Copyright by Thomas Jacobellis, 1981

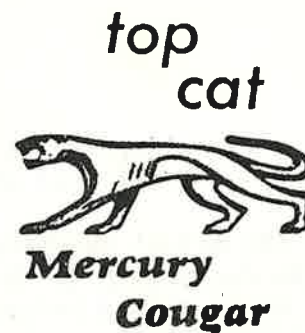

Posed beside his very well kept up 74 XR-7 is Barry Doyle #343 of Halifax, Nova Scotia, Canada. Barry has been the proud (lately) owner of this, his very first car, since the 21st of September, 1973. It couldn't have been a nicer first car to own, as he had just completed school and was now starting work. He purchased it at a dealership in Charlottetown, Prince Edward Island, and kept most of the records and invoices since. Here's a rundown on the window sticker when it was purchased.

Cougar XR-7 Hardtop (65F)	\$4340
Upbeat cloth and vinyl upholstery	57.20 credit
Unique 3/4 vinyl roof, avocado	N.C.
F78x14 W.S.W. tires	52.40
Power steering	124.80
Sports console	82.40
AM radio	74.30
Protective body side moulding	37.00

Distribution and delivery
Total list price

146.00
\$4799.7

The actual purchase price was \$4250, plus tax. As a part of the deal Barry got the dealership to throw in a DURACOAT rustproofing job also.

As mentioned before, Barry is now the proud owner of his Cougar. He wasn't too happy with it shortly after he purchased it because of the many mechanical problems that showed up. Power steering problems, then the transmission needed a complete overhaul at 8000 miles, and the side windows also needed adjustment a few times to keep the weather from coming inside.

With these problems out of the way, Barry has put almost 97,000 miles on everything since purchasing it. He has modified the car in a couple of ways, but kept the original flavor and appearance of the XR-7 since its first day off the lot. "In cockpit" locking and release devices for the deck lid and hood have been installed, some 1974 Cougar emblems, and Lucas amber fog lights, and interval windshield wipers have been installed by him. Inside he put in an AM-FM-cassette stereo with genuine Ford speakers in such a way that he didn't have to cut up the vinyl interior. As a last thought, he did a minor EGR system modification under the hood which makes for better warm-ups and slightly better acceleration.

Repairs: (other than whats already been mentioned) Timing chain @ 34,500, a set of Hyd. valve lifters @ 69,000, Radiator @69,400, Gas tank @ 72,000, Front springs @88,000.

Specifications: V.I.N. 3F93H573543, powerplant 351 Cleveland-2V, Carburetor Motorcraft 2100-D, Transmission C-6, Axle 2.75:1 Traction Lok, Oil consumption is one quart of genuine Ford 10W-40 per 2500 miles, used since new, Gas consumption is 11-13 MPG City and 17-20 MPG on the highway (all imperial gallons measurement). A detailed maintenance graph has been kept on the vehicle since new. Current estimated value is \$3,000.

As you can see, despite some early problems in which Barry was convinced he had a LEMON, he has really enjoyed his XR-7 since. We hope you keep on liking it in the future also.

THE TOP CAT

By Tom Jacobellis



Membership of the Cougar Club of America is now swollen to almost 800 members, plus many enquiries daily. All of our members who are currently paid up in full will be receiving some items soon in the mail, if they haven't already. You should have the club window decal and the membership card by now. The roster, after the updating will also be shipped later. The patches, sorry, are delayed one more time. However, just as soon as they are finished the paid members will receive one in the mail.

We still have a familiar problem. I need some of you with the gift of gab or those of you who enjoy showing off their Cougar to contact me.

Mike Cardinale's nice looking 68 XR-7 (#336)

I need some more local directors. Jeff Kent(#292)

To prospective new members--If you do not send in your \$12 Dues, you will not receive future Newsletters, Decals, Club Patches, etc. JOIN NOW AND KEEP COUGARS MORE VALUABLE AND ALIVE.

has now taken over the post of National Director. He will take over the post of coordinating the regional directors. Those wanting to become, or just curious, a regional director should contact him or me.

I also am still in need of some one in the New York area to become the club treasurer. All those interested please contact me, as the club account in a New York bank.

Some events are coming up shortly which I plan on attending and hope some of the other C.C.A. members will attend also. I'll be at the Humane Society Antique Auto Show, June 28, 1981. You can contact me, or them at Box 675, Monroe, N.Y., 10950 for more info. Also, I'll be attending the Long Island Region S.A.A.C. meet held on July 19, 1981 at SAYVILLE FORD, L.I., N.Y. For more info on this one contact: L.I. Region S.A.A.C. PO Box 175, Moriches, N.Y. The pre-reg fee is \$5.00. See you there!!

Steve Slater #628 is president of the Vintage Cougar Motorcar Club of San Diego. He has 15 members in the San Diego area so far, and invites those in the So. Cal. area to join in with them.

I myself am purchasing a 1970 Eliminator which used to have a 428 CJ under the hood. One of the rare options, as see the quantities thereof in this newsletter. Bill Veach, our printer, also just recently purchased a 69 Eliminator. Jim Rakowsky, our club historian is also presently trying to obtain an Eliminator from a local resident. Seems like Eliminators are about the best buy in the performance car market so far.

Address changes to the membership roster as follows:

#485 Ronald Block 22528 Flamingo Street, Woodland Hills, Ca. 91364

#555 John Olson 101 S. Arthur, Park Ridge Ill. 60068

#153 Kevin Marti 3507 West Krall Phoenix Az.

#71 is Lance Myers

#82 Bob Fischer c/o Fischer Classics, R.Rte 1 Box 212, Montpeller Va. 23192

#342 Kenneth Sutterlin, 1144 Frost Place, Fairfield Ca. 94533

#40 Mark Sink 3444 Mount Pleasant Blvd. Roanoke Va. 24014

#19 Richard Martin (Tech. Advsr.) zip is 80303

#307 Jim Rakowsky 18660 Rivercliff Dr. Fairview Park Ohio 44126

#343 Barry Doyle 1448 Brenton #23, Halifax N.S. B3J 2K7 Canada

SUPER STUDS by R.L. Martin

As I sat half listening to the squadron flight leader mapping out my morning mission, all I could think of was the BRUTE power I would be commanding from that camouflaged phantom (F-4E) sitting over there. I walked across the flightline and I could see her against the rising sun. I smelled burning JP-4 (jet fuel) filling my nostrils. This heightened my anxiety and desires to "climb aboard" and become one with the aircraft that would make me unique and a member of the the Winged Elite.

Having performed my pre-flight inspection, I climbed aboard and strapped in. After I did all of the cockpit checks, I hit the ignition and heard the power plant come to life with a loud CRACK then a constant ROAR. Brute-Total-POWER, and it was all mine to race against the sun with.

It was time now. The safety pins removed, and I heard clearance come from the tower. Everything was clear ahead. With my foot on the brake, I hit the throttle and revved her up a few times just to clear clear her throat. The moment had come I shoved the throttle to the floor I released the brakes GREEN LIGHT and BOOM!!! The afterburner kicked in and the tires really began to squeal and smoke from the terrific thrust of this engine upon them.

I was immediately forced back into my seat. Faster and faster I began to move. That roar of the engine became deafening! The markers along the edge of the roadway went by my window like straw in the wind. Flaps up! Wheels up! I was airborne and about to go into orbit and the world behind me looked like a speck of dust on my glasses.

I was alone, and flying along faster than I'd ever been before. I was in seventh heaven (or as close to it as possible). All of a sudden red lights and sirens went off in my head! Oh-oh, somethings wrong. I pulled the throttle back, dropped my flaps and speed brake, then lowered the landing gear, and came in for a landing. With my heart still pounding and my eyes watered, I looked out over the left side of the craft. There stood a man looking at me. I opened up the canopy and he excitedly began yelling at me-- Do you realize just how fast you were going back there (I dun't know, maybe a hunert maybe a zillion)?

Well, you blasted off like an astronaut hangin' onto a moon rocket or sumthin! Hey, why you is even wearin a FLIGHT SUIT!

Most of us while we drive our Cougars associate them with a finely tuned machine like a jet fighter aircraft or something really fast. There are though two special Cougars out there in the Wild Blue Yonder that might be considered as the ultimate cats. They were the Boss 429 Cougars. Ford Motor Company in late 1968 created a small company to modify its production Mustang Mach I's to accept their infamous Boss 429 c.i.d. High Output engines. The company was called Kar Kraft.

In April of 1969, Ford decided to modify two Cougars for promotional purposes. These cars sat around K.K. for several months, before work was started on them. Not only was the drive train modified, but so was the body. Various panels were changed to make them more resemble 1970 models. K.K. assigned these cars numbers K.K.1684 and K.K.1685. These cars were prepared for the National Hot Rod Assn's drag and show circuit, and used mainly by Dyno Don Nicholson and Fast Eddy Schartman.

Car Craft magazine did a drag test on a 1970 Boss 429 Cougar in their November 1969 issue. They stated the car that they tested was also equipped with the Ford built four speed, 2.54:1 first gear, a 3.91 9" Detroit Locker axle and F60-15 Polyglass tires on the Eliminator. The car weighed in at 200 pounds more than a comparable Mustang. Its best $\frac{1}{4}$ mile E.T. was 13.83, and 102.10 MPH. Shifts were at 5500 RPM. If any of the members know of these cars more, have some pictures while in action, or know of the present whereabouts, let us know.

Dick Martin

A special thanks to Steve Strange of the Boss 429 Registry, and Pete Sessler of the Super Ford Magazine.

THE CAT'S LITTER - STATISTICS AND PRICES ON THE 1970 MODELS

65A	47,279	Cougars with 428CJ	965
65B	18,565	Ram Air 428	None
65A	2,200 Eliminators	Boss 429	See Art.
76A	2,322 Conv.	Conv. with 428	74
76B	1,977 Conv. XR-7	Sunroof equipped	663

Total production of all Cougars was off dramatically for the 1970 model year. 72,343 units total being sold. Whereas 100,069 Cougars were produced in 1969. Convertible sales/ production dropped off better than one half from 1969. In Dearborn they were saying that surely the 71 models will mean a comeback for Cougar.

Average miles per gallon was 10-17, and common trouble spots were clutch, cooling system, suspension, and the electrical and ignition systems.

Of the options available, this is the percentage breakdown on how the Cougars

were equipped: 92.2% had automatic transmissions, 5% had three speed transmissions, 2.8% had four speeds, 95.6% had power steering, 67.6% had power disc brakes, 12.1% came with tilt steering column, 5.9% had power windows, 63.9% used tinted glass, and 61.9% had air conditioning.

Two door Hardtop--\$3114.00, Two door Convertible--\$3480.00, XR-7 Hardtop--\$3413.00 XR-7 Convertible--\$3692.00. Basic Specifications: Length--196.1", Width--74.1" Wheel base--111.1" Height--51.3", Weight 3431 lbs., Wheel tread F-60.5", R-60"

Engines: 351 CID 2V V-8(250HP)--Standard, except Eliminator. 351 CID 4V V-8(300HP) Standard on Eliminators, others \$53.20, Cobra Jet 428 CID 4V V-8(335HP) \$310.90, HO 302 CID (Boss) 4V V-8(290HP) available only on Eliminators- \$388.60

Transmissions: 3 speed manual standard all models, Select Shift automatic- for 351 CID 2V engines, \$206.10, -for 351CID 4V and 428CJ 4V engines, \$227.00, four speed manual with Hurst shifter, \$204.70 Note; the 3 speed Man. N.A. on HO 302 & 428CJ.

Selected optional equipment

Air conditioner,Whisper-Air	\$375.70
Sports console.....	\$57.10
<u>Decor Group</u> (includes deluxe wheel covers, curb moldings, three spoke rim-blow steering wheel, custom-grade door and quarter trim, door courtesy lights, rear quarter arm rests, and comfort-weave vinyl high-back bucket seats).....	\$90.70
<u>Decor Group</u> with Eliminator package (does not include wheel covers and curb moldings).....	\$70.00
<u>Eliminator Package</u> (includes hub caps and trim rings, black grille, body tape stripes, front and rear spoilers, racing mirrors. black XR-7 type instrument panel).....	\$129.60
Emission control (California only).....	\$37.60
Glass, full tinted	\$32.40
Power Brakes, (front disc,rear drum).....	\$64.80
Power steering.....	\$104.90
Power windows.....	\$104.90
Radio-AM.....	\$60.90
Radio-AM/FM/Stereo (includes two door mounted speakers).....	\$212.50
Radio-AM Stereo tape (includes two door mounted speakers)...	\$195.60
Vinyl Roof.....	\$89.40
Steering Wheel-Tilt.....	\$45.40
Steering Wheel-Rim blow (included in Decor Group).....	\$35.00
Sun Roof (power operated).....	\$375.70
Tires, white sidewall (E78x14).....	\$29.80
Tires, white sidewall, fiberglass belted (F-70,over E-78 BSW)	\$63.50
Wheel covers, Deluxe (unique wheel covers standard on XR-7).	\$25.90

OK FINE, but how many of my car was made? Figures of percentages don't usually mean too much to some folks, but they should. So look through your drawers and find that electronic calculator you got awhile ago to do your income tax, and

maybe we can figure out a rough figure on your particular model of Cougar. If you don't own a 70, dig out the previous Sign of the Cat which has figures on your year of Cougar. If you own a later than 1970 model, you'll have to wait for the next issue of At The Sign of the Cat which applies to your model.

Now lets figure this out. I'll use my own Cougar as an example. You'll have to substitute the production figures and percentages into the applicable slots.

My 1970 Eliminator- 2200 units. This is the starting point to get the best estimate for your car. This figure must be the smallest in the statistics which still describes your car best. If my car was sun roof equipped, I'd use 663. However, my car fits one statistic just a little better. It came with the optional 428CJ, so I'll use 965, as it is the smallest of the statistics which fits my car best. So, I know that my car is at least (or best) 1 car in 965. Of the 1970 total of 72,343 units, only 965 came with 428's, or less than one percent came so equipped.

Lets continue then to find a wish' figure on my (or your) Cougar. As it came with some popular options, and without some popular options. Fourspeeds-- using the transmission figure of 2.8%, and multiplying it by the production figure of 965 we get 27.02 units, so equipped being built.

965 times .028 (this is 2.8%) equals 27.02

Decimal place are dropped, as who ever heard of 2/100ths of a Cougar being made (that excludes parts). So far my Cougar is one of 27 being "So Equipped" built.

Now the car did not come with power steering, so the percentage figure is wrong, but it can be adjusted. Did is the oposite of did not, so then 100% minus 95.6% equals 4.4%, or then 4.4% "did not come equipped" with power steering. Then--

(1 in 27) 27 times .044 equals 1.2 units.

This is as low as you can go obviously. The car could very well be unique, one of a kind. Right? WRONG! These percentages can be worked to your advantage, and are at best just a guess. You must consider "Required" equipment. If a certain option was required when ordering, often you can't take advantage of the figure. Such as power disc brakes. Now power disc brakes were required on 428's. Thus I couldn't multiply my original 965 figure by 67.6%, because all 965 had power disc brakes. You have to watch the figures and know your required options a little.

Lets figure a more normal Cougar. The basic 65A with and without some of the popular options.

47,279 units (65A), automatic transmission, power steering, power brakes, air conditioning and tinted glass.

So, 47,279 X .922 (AT) = 43,591 Then 43,591 X .676 (PDB) = 29,467
 Then 29,467 X .617 (Air) = 18,181 Then 18,181 X .639 (Glass) = 11,618
 Then 11,618 X .879 (No tilt wheel) = 10,212 Then 10,212 X .941 (No P. Wind.) = 9610

One car in 9610. Now there's an awfull lot of "Wish" in this figure, as it makes every car seem like a rare and valuable one, or so the owner WISHES. The true value of the car is determined by desirability, not always rareness, but rareness usually helps. You must use some common sence and the "Options" list. Most XR-7's came fully equipped, the 65A's somewhat less, and the Eliminators less yet. You might want to take an average figure or use the smallest one only, as you're sure on at least one, the statistic.

CAT TRACKS by Dick Martin Technical Director

Q; How can I tell where my car made and what it originally came equipped with?
 A; Send me your serial number and an S.S.A.E.

Q; I have a big block (428) 70 Cougar with F-78 x14 tires on the front. They are wearing really bad on the edges, Why?

A; Assuming your front end is tight and aligned properly, I'd say there's too much

weight up front for those tires. Size G-78 or G-70 would be better. Check the tire/car load limit charts.

Q; What is the difference between a 6.5 litre and a G.T. Cougar?

A; Basically the G.T. and 6.5 litre plaque. Both were 390's and were equipped the same way. L.M. in Denver shows no difference --(District Parts)

Q; I own a 1970 Cougar with a 351 V-8. How do I tell if its a Cleveland or a Windsor engine?

A; Easiest way is by looking at the size of the valve covers. Large flat ones- its a Cleveland, smaller 302 size ones and its a Windsor. Also the fuel pump bolts are in different positions. Cleveland, they are one over another, and on Windsors they are side by side.

Q; My car has developed a snapping noise underneath, but it only happens when the car is moving. What is it?

A; Pull over quick. Sounds like a bad case of EL-BROKO U-JOINTO.

Many people have written to me asking for advice on what to do about their Cats "lack of spring in its paws". They complain of excessive swaying, plowing around corners and bottoming out. Your Cougar is no different suspension wise than the backbone on an older person or a jogger. After many years of constant pounding on our wonderful highways and roads, things tend to settle and weaken or in some cases break loose.

To restore your Cougar to its original youthfull self, there are many ways to go, depending on what your monetary wealth is and or how much you value your life.

The cheapest and by far the most dangerous way to go is by installing metal raising blocks between the front coils. This use creates uneven tension on the coils and could break a coil if a hard bump is hit. They also have a tendency to fall out at the wrong times. Using raiser blocks employs about the same belief as having temporary plastic fillings in your teeth.

The next type people use are the coil over the shock variety. These are better than using blocks by far, but they like the blocks don't cure the problem. Coil-shocks on occasions have been known to break loose at the top when installed in Big Block cars. No doubt this would be detrimental to a persons health if you were on a mountain road and this happened, and no doubt your Cougar wound up in the big sand box in the sky, before this time.

The best way for you to help your Cougar to regain its former majestic stature is to in stall new coil springs. A person can use blocks/coil-shocks and many other



351 WINDSOR GET'S OVER 20 MPG!

Here's Ned Flynn (#4), posed beside his nice personalized 69. 212,000 miles on it.

aftermarket junk, all these won't cure the main problem. Lincoln-Mercury parts still offer most of the stock coils that were made for your car. The dealer can advise you on which coil to get, or send me a note and maybe I can be of some help. There are roughly 10 different load weight springs available and its best to get the one made for your car at present.

If for some reason you want to raise your car up more than stock, just go to the next higher weight limit. If you really want to raise your Cougar, order a set of High-Lift springs through J.C. Whitney. These springs will raise your car 3-4" and are excelent for \$45.00 a pair. Remember though your center of gravity is calibrated in reference to your car's weight etc. So if you raise the height above stock you will affect the stability accordingly.

While you have the front end apart, it should be totally inspected for wear. Ball joints, idler arm, tie rod ends, etc. should be replaced even if slightly worn, especially on cars with Big Blocks. How much you replace that needs replacing can only be judged on the value you place on your life.

Rear springs are a different matter, they can either be replaced with new leafs or the use of coil/shocks or air lifts may be used. All work just as well. It just depends on whar purpose your car serves. If you pull a heavy trailer or carry cement blocks in the trunk, you'd better use air shocks.

I hope this comes in handy to you. Remember the better your suspension, brakes, and tires are the safer you are and your passengers. Anyone can paint a car to look good, its whats underneath that counts also.

Dick

MEOW MIX

Car Exchange magazine had a nice article on how to use your local library's Guide to Periodical Literature. This would be beneficial in research, upholstery, and general auto repair. (Car Exchange Vol.2, No.9, Iola, Wisc.)

The 67 Cougar convertible you saw it the last Cat belongs to Kevin Marti, of Phoenix Arizona. He will be filling us all in a little later on just how he did this conversion from a hardtop.

When sticking the club decal to the window, I found that it picked up finger prints very easy, and tended to leap out of my hands due to static. Be careful when getting it near the glass to position it square before it gets near the glass. Putting a slight curl in it will allow it to touch at only one point first. Then slowly work it from the center out. Pop any air bubles with a pin and press again. Use a sharp single edge razor blade to trim around the outside ring and then your fingerprints can be peeled off.

The 1967 Mercury Trans Am Team question must have been a tough one for some of you. No one who has written me has come near 100% yet. I'll let it run just a little longer. Some of you are getting the S.C.C.A. Trans Am series mixed up with NASCAR's Baby Grand races. Look in to those sportscar type magazines for some help. They usually have pictures of the series, as the Cougar team was the one most people were rooting for, and thus got a lot of coverage. Here's a little help. The Sept. 17, 1967 Mission Bell 250 at Riverside Cal. was won by David Pearson driving the #15 Cougar of the Bud Moore team. Ed Leslie drove #98 to second, and Allen Moffat brought #41 in to 28th position. If you went down to your local library and nosed through their back issues of newspapers and magazines it'll tell you who drove, but not always their numbers. There were 11 races in 67. If you were lucky enough to get a copy of the print "Finish Line At Daytona" which was offered by Autolite showing two team Cougars, don't believe the numbers.

STAFF MEMBERS.

Membership & Classifieds
Tom Jacobellis
1526 Ericson Place
Bronx, New York 10461

The Cat's Editor
W.P.Kaminsky
273½ E. 6th St.
Beaumont, Ca. 92223

Cat Tracks
Dick Martin
1720 Lehigh St.
Boulder, Colo. 80303

Regional Director
Jeff Kent
1617 Center Ave.
Iowa City, Ia. 52240

Historian
Jim Rakowsky
18660 Rivercliff Dr.
Fairview Park, OH 44126

Printer
Bill Veach
6820 N.W. 6th Dr.
Des Moines, Ia. 50313

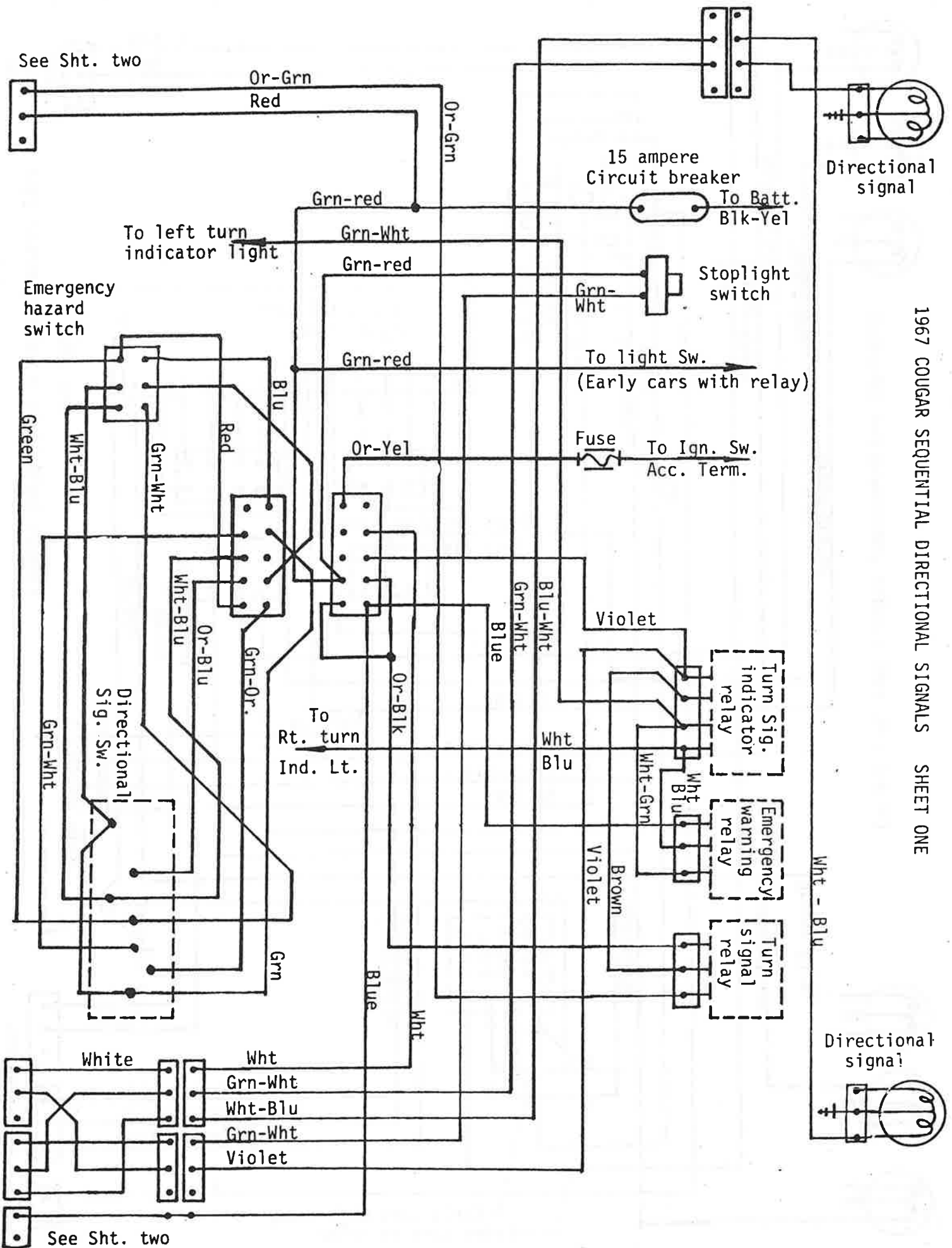

1967 COUGAR SEQUENTIAL DIRECTIONAL SIGNALS

SHEET TWO

See Sht. One

See Sheet One

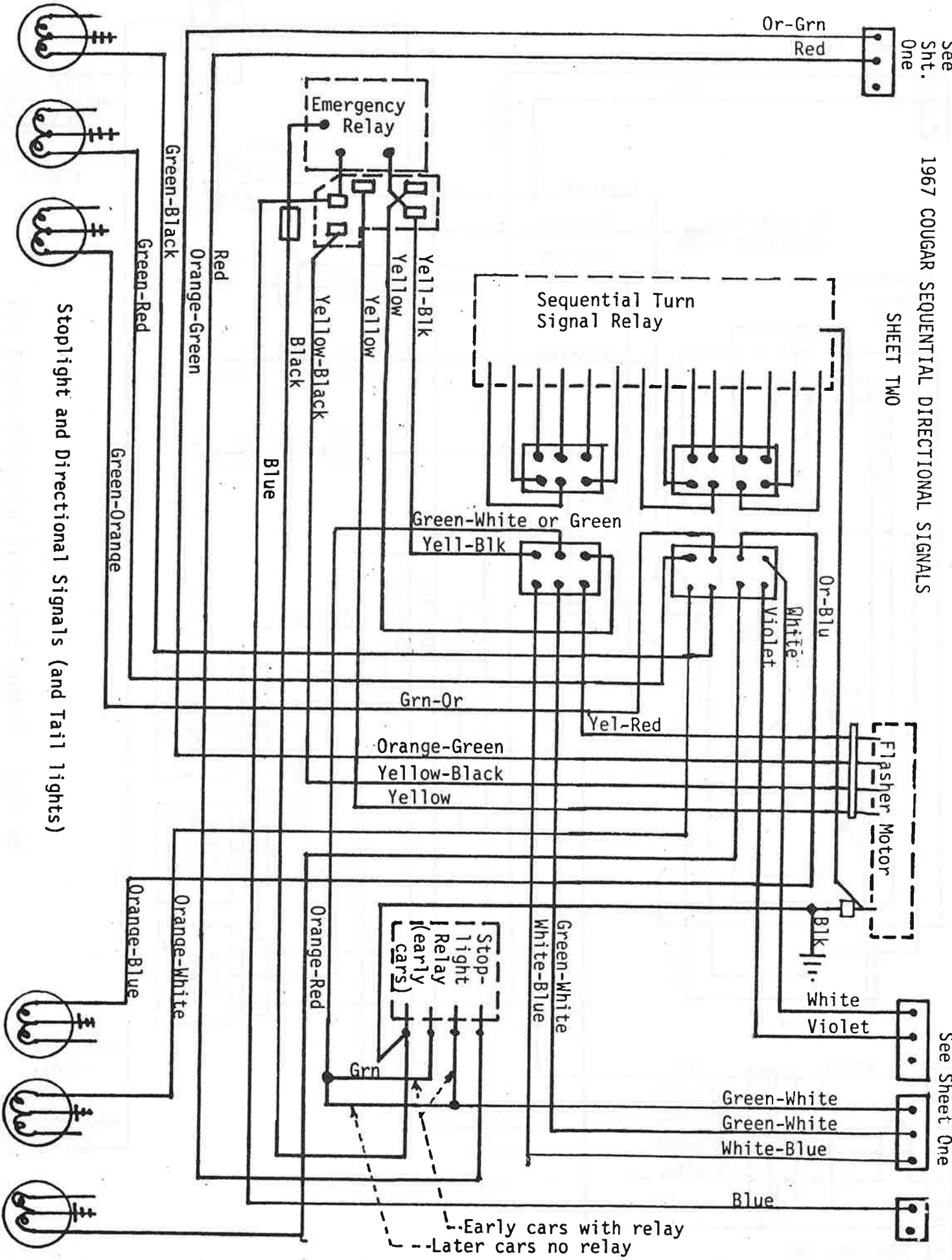

COUGAR CLASSIFIEDS

FOR SALE: We have just received 20 original owners' manuals for '67 - '73 Cougars - are \$2.50 each + .50¢ postage - Send S.A.S.E. if no longer available... Write: C.C. of A.

FOR SALE: '69 - '70 Blk, blue dash pads - \$50.00 each, '69 - '70 Convertible boot covers, dark green, tan, white, saddle - \$25.00 each... '70 tilt steering column w/key - \$100.00, '69 tinted glass door & ¼ window - off track - \$40.00 all, '69 - '70 consoles - black \$35.00 each, '70 reg. steering column \$25.00.. '69 steering wheel padded center plain \$10.00 w/w motors \$10.00 each, '69 - '70 convertible top motors \$40.00 each, '69 - '70 convertible top irons & cylinders - no material \$50.00, '69 headlight grille covers \$10.00 pair, '69 - '70 \$10.00 pr, '69 - '70 taillights w/chrome \$15.00 each, headlight vacuum motors \$15.00 each, M/T alum finned valve covers, says FORD on outside 427 on inside \$20.00 pair... have or can get factory AM/FM & AM/8-track radios and hubcaps.. write your needs S.A.S.E. Write: Tom Jacobellis, 1526 Ericson Place, Bronx, New York 10461... Phone: (212) 892-3849.

WANTED: Padded dash for '67 Cougar, Write: Don Pierce, 1013 San Mateo, SE Albuquerque, New Mexico 87108.

ANYONE INTERESTED IN HAVING '71 - '73 door panels reproduced
Write to: Ron Weaver, 1228 Capri Drive, Crestwood, Montana 63126
Needs about 250 orders!!

Gary Hinkle has all kinds of '67 - '73 Cougar literature,
Write to: Auto-West Advertising, P.O. Box 3875, Modesto,
California 95352.

FOR SALE: 1973 Convertible - lots of extras, Write: Hon. Robert J. Hallisey, The Superior Court, New Bedford, Massachusetts 02740.

WANTED: For '69 set of rear window cranks and rear interior - ¼ panels black color, Write: Paul Bare, 13026 Lk. Magdalene Blvd, Tampa, Florida 33618.

BILL'S MUSTANG PARTS, 8648 Maple, Bridgeport, Michigan 48722
Has free list of COUGAR and Mustang parts.

FOR SALE: '67 XR-7 GT, perfect body, new black paint, factory mags, ps, pb, tilt wheel, \$2,000.00 firm, delivery possible, Write: Mike Schehen, 28199 Bodenhammer Road, Eugene, Oregon 97402, Call 1-503-688-3986.

WANTED: Factory cruise control for '69 Cougar, would consider whole car if ruff... Write: Aaron Gardner, R3 Box 106, Van Wert, Ohio 45891, Call collect 419-238-4021

WANTED: Steel styled wheels for '71 XR-7, NOS or exc. used, Write: Harry Grieshaber, 4611 Catalina Drive, San Jose, California 95129, Phone: (408) 255-9680.

- WANTED: '69 Eliminator, 351, auto, prefer black interior and vinyl roof, also want grille; fender well mouldings, signal light indicators, rear taillights, Write: Robert Purcell, 76 Bridge Street, Hatfield, Massachusetts -1038 Call 1-(413) 247-5256.
- FOR SALE: HAS YOUR LOW FUEL WARNING LIGHT QUIT?? OFFERING REPLACEMENT LOW FUEL THERMISTOR ASSEMBLES FOR '67 - '70 XR-7's, \$15.00 each. I need 50 more orders before these can be made. Those who ordered all checks will be held or returned. Electronic REPLACEMENT FOR '67-'68 turn sequencer \$30.00, USED: '68 tilt away column \$75.00, Uncracked soft black dash pad \$45.00, '67 style steel wheels \$50.00 pair, '69 deck lid \$20.00, '69 drivers door w/PW no motor \$20.00, low riser 427 dual quad manifold w/carbs \$150.00, Write: V.R. Yarberry, 7105 Winans Drive NE, Albuquerque, New Mexico 87109.
- WANTED: N.O.S. or used RAM AIR CLEANER for 428CJ, Write: Jim Rakowsky.
- FOR SALE: Complete disc brakes for '68 GT, fits other years, '71 - '73 woodgrain rimblow wheel perfect, +++ more parts, send needs and S.A.S.E., Write: Karl Baker, 1709 Hollywood Way, Burbank, California 91505, Call (213) 845-5690.
- WANTED: '70 XR-7 Convertible - brown interior trim parts, weatherstrip, style steel wheels, tilt column, speed control, excellent condition only, Write: Bob Booth, 6661 Banning Drive, Oakland, California 94611, Phone (415) 531-2211.
- WANTED: '70 black Eliminator door panels, plain radio heater cover, & stripe kit #DOWY-6520000-A, 351C 4bbl manifolds, cast iron or aluminum dual or single plain, Write: Harry Hodson, 1800 Ontarioville Road, Apt. 217A, Hanover Park, Illinois 60103.
- FOR SALE: '70 Boss 302 Eliminator new paint Calypso coral, tires, brakes, interior, headers, exhaust - all new, 3:50 posi, has 351C-original 302 completely rebuilt and not installed yet \$2,200.00 w/o 302 engine \$3,200.00 with, Write: John Rollyson, Rt. 24 Box 1110, Baldwin, Florida 32234 - Call (904) 266-9258.
- WANTED: Rear spoiler for '69 Cougar, Write: John Dyches, PO Box 634, 1134 3rd Street So. Naples, Florida 33939. Also info on super charges for 351W.
- WANTED: '68 XR-7G, 302 - 4 spd, ps, air, restorable only, Write: R. Martin, 1720 Lehigh, Boulder, Colorado 80303, Also '72 - '73 Montego ram air system, or GTE.
- WANTED: Passenger side front fender '67 - '68, Write: Mark Forsythe, 11359 Hemingway, Redford, Michigan 48239, Phone (313) 937-8927.

CLASSIFIEDS CONT'D)

WANTED: '68 XR-7G parts, wheels, caps, scoops anything, dark blue and tan leather seats for '68, big block cast valve covers w/cougar inlay, also would like to correspond with other XR-7G owners also selling '69 - '70 hood scoop, '68 day/night mirror '68 clock w/black console front for '67 - '68, make offer, Write: Laurence Juhnke, 11604 S.E. Lancaster Road, Portland, Oregon 97219.

FOR SALE: '68 XR-7, 302 auto, ps, AM/FM stereo, yellow, black roof and interior, 62,000 miles, excellent cond. \$3,295.00.. Might trade for '57 Ford Fairlane or Ford Pickup - in excellent cond., Write: Bob Russell, 12 Lasky Road, Beacon Falls, Connecticut 06403.

FOR SALE: '69 compressor and all hoses, pair of window canals, side emblems for '69, Write: Jeff Wallace, 8300 Cathedral, Forest Drive, Fairfax Street, Virginia.

WANTED: Center grille and right side grille for '70, also hood scoop from an Eliminator, Write: Paul Geotis, 142 W. Main Street, Dudley, Massachusetts 01570.

FOR SALE: '67 Dan Gurney Spl, 289-2V C4, Mint original, 122,000, Write: Jeff Baumsteiger, 100 Alta Vista Avenue, San Anselmo, California 94960.

WANTED: For '67 Cougar, L.H. remote sideview mirror, nos or exc, rear $\frac{1}{4}$ window cranks, back-up light lens, L&R outside rear $\frac{1}{4}$ window outside chrome, door guard chrome strip, R&L outside vertical rubber weatherstrip, nos, Write: Richard Phillips, 1919 Las Tunas Road, Santa Barbara, California 93103.

FOR SALE: '68 XR-7G, auto, PS, PB, AM/FM cassette, new radials, brakes & paint, 390, asking \$4,700.00, Write: Michael LaMendola, 440 Live Oak Loop NE, Albuquerque, New Mexico 87122.

WANTED: Hydraulic top cylinder for '71 Convertible, Write: Robert Prescott, 1180 Skyline Drive, Covington, Georgia 30209.

FOR SALE: Dk. green leather front seat '69, also tilt wheel -- offers -- shop manual for '69, tilt wheel, beige, parts catalog for '69 Write: Allan Davies, 36 Hallow Cres. Rexdale, Ontario, Canada M9W 2V9.

WANTED: Left rear $\frac{1}{4}$ panel #DOWY 6527841-C, gas cap door lower moulding & ornament #C9WY654A48-B&C9WY65405A86-A, taillight housings and $\frac{1}{4}$ window chrome also needed, Write" Carey Rittinger, 60 Belmont Avenue, W. Kitcher, Ontario, Canada N2M 1L4.

WANTED: '67 - '68 rear $\frac{1}{4}$ panel drivers side, Write: David Denney, Rt. 1, Box 222, Palmyra, Indiana 47164.

THE FOLLOWING MEMBERS HAVE HAD ADDRESS CHANGES:

John Dyches, 1134 3rd St, South, Naples, Florida 33939

James Dunn, 1665 Long Bow La, Clearwater, Florida 33516.

CLASSIFIEDS CONT'D

Mem. No. 343 - Barry J. Doyle, 1448 Brenton St. Apt. 23, Halifax,
N.S. Canada B3J 2K7

Ross Hayduk, #301-9821, 156 St., Edmonton, Alberta, Canada T5P 2G2

Mem. No. 444 - David Denney, Rt. 1, Box 222, Palmyra, Indiana 47164.

DON'T FORGET TO SEND IN THOSE WANT ADS AND FOR SALE ADS FOR THE
NEWSLETTER. ALSO, SEND IN THOSE B&W PHOTOS OF SELF AND CAR AND
LITTLE STORY FOR FUTURE NEWSLETTERS.

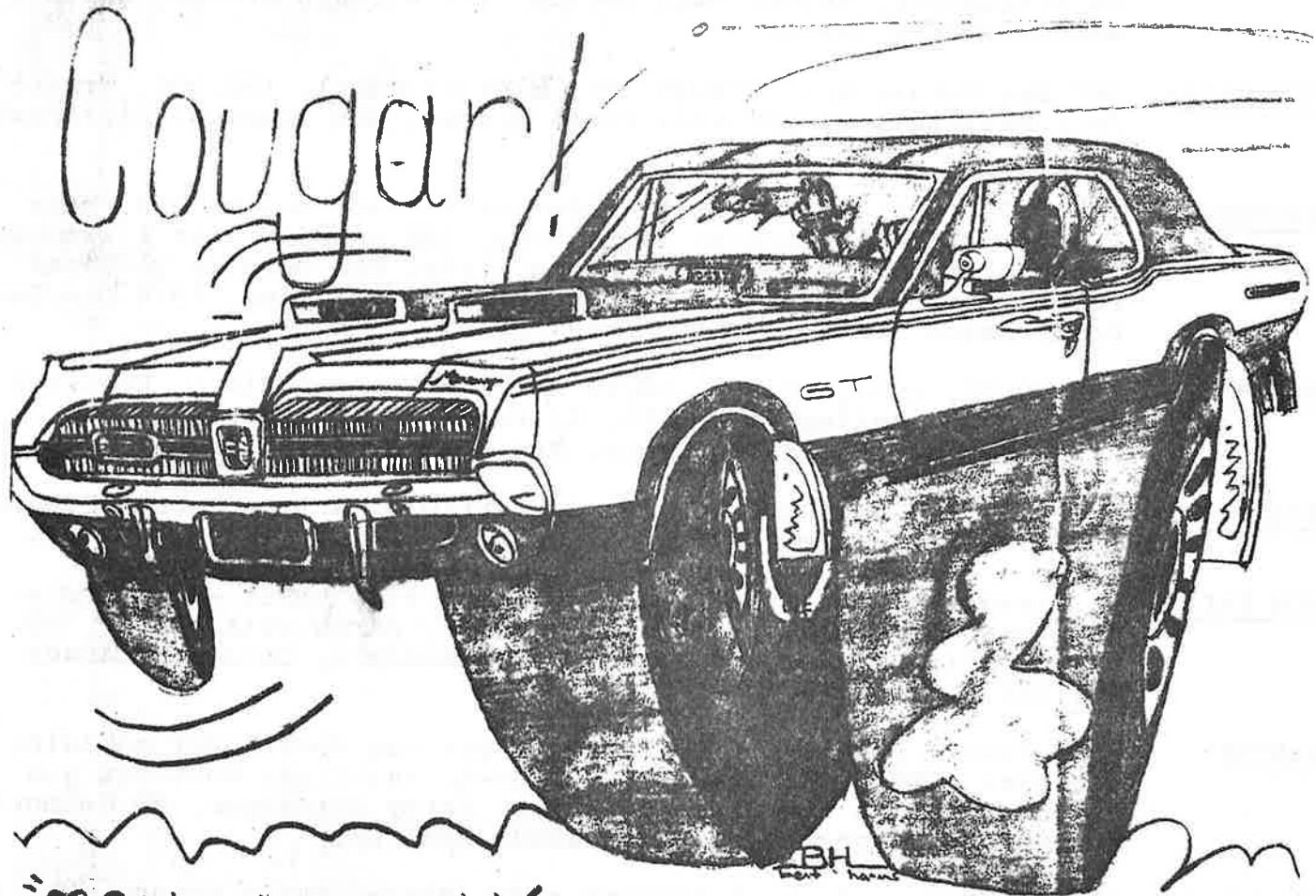

"meet the world's sharpest car"

627. John Swanson
76 Amsterdam Rd.
Smithtown, N.Y. 11787
'73 XR-7
628. Steve Slater
3634 Jackdaw St.
San Diego, CA. 92103
Pres. Vintage Cougar
Club of California
629. Stuart Danby
1628 Newton Rd.
Orlando, Fla. 32808
630. Malcom Massey
Rt 7, Box 591
Columbus, Miss. 39701
631. Ernest Pyle
2522 Kittiwake, Dr.
Brookmeade, Wilmington
DE. 19805
632. Charles Giannotti Jr,
Rt 14 Box K-57
Richmond, VA. 23231
(70 Eliminator
633. Jim Smith
837 Eden Rd.
Lancaster, PA. 17601
634. Dan Boatright
Rt 13,
Lincoln, NE. 68505
635. William Spinosa
39 Maple Rd.
Woorheesville, N.Y. 12186
'67
636. E. Doering
B 312-275 Clearview Av.
Williams Lake, B.C. Canada
V2G 4H6 '67 XR-7
637. Larry Williams
PO Box 1183
Brooksville, Fla.
33512 '67 & '68
638. Robert Harelstad
Box 31 Rt. 4,
Chetek, Wisc. 54728
639. John Donnelly
RFD 783
Edgartown, MASS.
02539 '70 XR-7
640. George Kennedy
c/o RAYCHEM Corp.
2700 Cumberland Pkwy.
Suite 130, Atlanta, GA.
30339 '68 XR-7
641. Joseph Frost
5305 C.R. 37
Rawson, Ohio 45881
'69 conv.
642. John Pullman
542 Chestnut St.,
N. Tonawanda, N.Y.
14120 '69
643. Tommy Loomas
P.O. Box 211
East Prairie, TX.
63845 '70 XR conv.
644. Mark Morian
707 Fairhill Dr
Louisville, KY. 40207
'68 XR-7GT
645. Dan & Debbie Volk
640 Stevenot Ct.
Turlock, CA. 95380
646. Den Bass c/o Dutch Maid
Ice Cream Co. Ltd. 197 Osborne
St. Winnipeg, Manitoba, Can. R3L
1Z4 '69 Conv.
647. Jeff Cox
1620 Tweed St.
Rockville, MD. 20851
Wants '67-'68
648. Norman Ford
6806 Perry Penny Dr.
Annandale, VA. 22003
649. Richard Budd
1635 S. Roosevelt
Wichita, KS. 67218
'68 XR-7GT
650. Robert McClellan Jr.
1351 Logan Ave.
Tyrone, PA. 16686
'68 D.G. Spl.
651. Daniel DePardo
CO-E USA/GS Box 1069
FT. Huachuca, AZ. 85613
'68
652. William Rutherford
RD 1, Box 56A,
Tyrone, PA. 16886
'68 & '69 428CJ-RA
653. Stephen Tankersley
Rt 6 Box 78
Weatherford, TX. 76086
654. Steve Hecht
117 S. Hillcrest
Ogallala, Nebraska
69153
655. Harry Grieshaber
4611 Catalina Dr/
San Jose, CA. 95129
'71 XR-7 conv.
656. John Ramik
207 Oak Ridge Rd.
Startford, Conn. 06497

657. Paul Devine
18 Willowbrook Pl.
St. Charles, MO. 63301
'71 XR-7
658. Tim Schrupp
1028 Branham Ln.
San Jose, CA. 95136
'68
659. Mike Wentz
Box 243
Firth, NE. 68358
'67
660. Jon Trusewicz
10 Butler Pl.
Haskell, N.J. 07420
'67
661. Rick Bover
1305 8th ST. NW #4
Minot, ND. 58701
'70
662. James Taggart
38 Norman Allen St.
Elkton, MD. 21921
'69
663. Stephen Boyce c/o
Rush's Music
2868 Alcoa Hwy.
Knoxville, TN. 37920
664. Todd Batory
402 E. Bucyrus
Crestline, Ohio
44827 '69 Elim, '67
665. Jim Severson
959 Gilrust
Stoughton, WI. 53589
'68 XR-7
666. Eugene Krumenacker
Lucas Rd.
RD#2, P
Phoenixville, PA.
19460
667. Harry Hodson, Apt. 217a
1800 Ontarioville Rd.
Hanover Park, Ill.
60103 '70 Elim.
668. Robert Davis Jr.
1351 Avondale Ave.
Jacksonville, Fla.
32205
669. Frank Zaludek
3719 E. Candor St.
Lakewood, Fla. 90712
670. Ron Bradley
435 E 10th Apt 4,
Anchorage, Alaska
99501
671. Donald Johnson
RT. 2, Box 162
Villisca, Iowa 50864
672. Ted Hakas
650 Beatty Rd.,
Monroeville, PA.
15146 '73 XR-conv.
673. Larry Brown
3496 Rosendale Rd.
Schenectady, N.Y. 12309
674. Frank Holman
13 Hilltop Ct.,
Jamesburg, N. Jersey,
08831
675. Mike Friggens
1218 Los Arboles
Albuquerque, N.M.
87107
676. Micheal Bauer
1502 West Yakima Ave.
Yakima, Wash. 98902
677. Philip Kyme
3 Reineman St.
Albany, N.Y. 12203
678. Albert Faragher
318 W 3rd Ave. N.
Aurora, Minn. 55705
679. Ken Barnette
628 Cooper Dr.
Charlotte, N.C.
28210
680. V.M. Downey
2222 Lakeview Ave.
Richmond, VA. 23220
681. Samuel Snyder
P.O. Box 5605
Fort Wayne, Ind. 46895
682. Jerome Hawkins
57 Sumner St.,
Hartford, Conn/
06105
683. Jeanette Edmondson
Rt. 1, Box 707
King, N.C. 27021
684. A. Cascigni
4197 Pardee Lake Rd.
Howell, Mich. 48843
685. Paul Bare
13026 Lake Magdalene Blvd;
Tampa, Fla. 33618
'69
686. AMN. David Knotts,
PSC#1, Box 906,
E-AFB, Rapid City, So. DAK
57706-5021

687. Ian Macleod
69 Danes Way,
Bishops Estate, Brentwood
Essex, England, CM15 95T
688. James Stentz
PO Box 1289,
Lake Oswego, OR.
97034
689. Bruce Flynn
P.O. Box 252,
Rockdale 2216, Australia
'68 XR-7
690. William Bogert
631 Albert Pl.
Ridgewood, N.J. 07450
691. Keith Armitage
2441 Oakview Dr.
Rochester, N.Y. 14617
'73
692. Richard Crowe
318 Rambling Way
Springfield, PA.
19064 '67GT
693. Paul Scott c
636 Fulton St.,
Hannibal, N.Y. 13074
'69 Elim.
694. Jeanne Hawkinson
6405 Culmore
Houston, Texas
77087 '70
695. Michael Krohne
53 Inman Ave.
Colonia, N.J. 07067
'73 XR-7
696. Robert Purcell
76 Bridge St.,
Hatfield, Mass.
01038
697. Brian Scheel
P.O. Box 2014,
Des Moines, IA.
50310 '67XR-7
698. Gary Rogers
314 Laurel Hill Rd.
Allison, PA. 15101
699. Lee Harrison
box 407, Bryans Rd.
Bryans Road, MD. 20616
'70 Conv.
700. John Houck
310 Vassar Ct.
Ladson, S.C. 29456
701. Connie Onyschuk
#104, 11830 101 St.
Edmonton, Alberta, Canada
T5G-2B7 '67
702. Buford Hurley
1209 Hamef St.
Flatwoods, KY. 41139
703. J.D. Williams
587 N. Western,
St. Paul, MN. 55103
704. Jeff Conley
4146 Lake Park Blvd. Apt 36
Indpls, IND. 46227 '67 362B
705. Phil Butterbaugh
P.O. Box 136
Cassandra, PA. 15925
706. Rick Eggers
9410 E. Lurlene
Tucson, AZ. 85730
707. Jim Hord
301 W. Allen,
Clinton, MO. 64735
708. Gerard Guerrero
P.O. Box 308,
Honokaa, Hawaii
96727 '69
709. Ray Folkestad
901 2nd Ave. East
Williston, ND. 58801
'69 convertible
710. Mark Forsythe
11359 Hemingway
Redford, MI. 48239 '67-68
711. David Brown
Rt 6, Box 146
Fairmont, WV.
26554 '69XR conv.
712. Craig Grist
959 Custer St.,
Columbia, S.C. 29210
'67&68
713. Mike Kline
Rt. 1, Box 58A
Fairplay, MD. 21733
715. John Zondervan
7295 Rose Lane
Jenison, MI. 49428
'70 428CJ
714. Bob Letwinetz
18 Allenbrooke Apt 104,
Yorkton, SASK, Canada
S3N 2J7 '72
716. A.R. Hume
780 So. Main St.,
Mansfield, MA. 02048
'70&'71 XR-7

717. Charles Jensen
101 Sioux Ct.,
Negaunee, MI. 49866
718. Michael LaMendola
440 Live Oak Loop NE
Albuquerque, N.M. 87122
'68 XR-7G
719. John Barnette
628 Cooper Dr.,
Charlotte, N.C. 28210
720. Robert Lance
P.O. Box 502,
Arden, N.C. 28704
721. Russell Sprague
8800 Greens La.
Randallstown, MD.
21133 '68GT&69conv.
722. Bill Hansel
1234 W. Dolores St.
Wilmington, CA. 90744
68&69XRconv w/428CJ
723. Tim Hemsoth
1459 Northland,
Lakewood, Ohio 44107
'69 Elim w/428CJ
724. James Banning
1746-17 Cloister
Crosby, TX. 77532
725. Philip Rohr
RR#3,
Bryan, Ohio 43506
726. Douglas Kowall
11125 Pam La.
Creve Coeur, MO. 63141
727. Tony Tatterelli
4725 Springbrook Dr.
Annandale, VA. 22003
728. James Thompson
5629 Pier Dr.
Rockville, MD. 20851
729. Frank Lisiak
305 Racine St.
Waterford, WI.
53185 '67
730. Brett Van Dunk
20 Cooper Dr.
Manuet, N.Y. 10954
'69 conv.
731. Jimmy Payne c/o Payne's
Shell Station
Piedmont, S.C. 29673
'70 Eliminator
732. Wayne Smith
2601 Edgewood Ave.
Anderson, S.C. 29621
'70 Eliminator
733. Dr. Gordon L. Dorn PhD.
1232 Lausanne,
Dallas, Texas 75208
'69 Eliminator
734. Danny Boothe
105 Hob 'o the Hill
Sherwood Addition
Maybank, TX. 75116
735. Leo Meier
6402 Melody,
Dallas, TX. 75231
'67
736. John White
509 Brand La. #85
Houston, Texas 77477
737. John Desilets
1439 Buckingham Av.
Gastonia, N.C. 28052
738. Aaron Gardner
RR#3 Box 106
Van Wert, Ohio
45891
739. David Blasek
2409 Limerick Dr.
Tallahassee, Fla.
32308
740. Robert Peters
510 Jolesha Pl.
Alliance, Neb. 69301
741. Bill Moyer Apt#4
3711 Indian Run Dr.
Canfield, Ohio 44406
'68XR-7
742. Bruce Baidinger
205 S. Owen St.
Mt. Prospect, ILL.
60056 '73XR conv.
743. Tim Hurst
296 Roy Huie Rd Apt 10D
Riverdale, Ca. 30274
744. Tony Presto
1645 Lauren Ct.
Bensalem, PA. 19020
'71 XR-7 Conv.
745. Donald Bereiter,
409 Evans St.,
Uniontown, PA.
15401 '69XR-7
746. Michael Brunell
6333 Martinwood Dr.
Millington, Tenn. 38053
747. Lewis Heintzelman
2228 Belmont St.,
Allentown, PA. 18104
748. John Waha
1 Hokianga St.
Mangere East AKL.
New Zealand.
749. Janice Crum
RD#1, Box 101
Duncannon, PA. 17020

750. Ross Hayduk #105
10040-154 St.,
Edmonton, Alberta,
Canada T5P 2G9
751. Ron Lauver
46 Walton Ave.
Oakland, N.J. 07436
752. Lou Strnad
1206 15th S.W.
Cedar Rapids, Iowa
52404 '72
753. Ed Maskal
25 Kossuth St.
Haledon, N.J.
07508
754. Darryl Hager
Rt. 1,
Henley, MO.
65040
755. Marion Parker
1905 Raa Ave,
Tallahassee, Fla.
32303 '69
756. Larry Hunte Apt C-1
1318 Pickens
Columbia, S.C.
29201 '67
757. David Byers
Box 703
Salmon Arm, B.C.
Canada VOE 2T0
758. D. Campbell c/o
Southold Fishing ST.
Southold, N.Y. 11971
759. Thomas Carr
4780 96th ST. North
St. Petersburg, Fla.
33708
760. Steve Adolf
1124 Franklin Ave.
Louisville, CO.
80027 '71XR conv.
761. Lori Friedman
6459 Chiltern Rd. N.W.
Canal Fulton, Ohio
44614 '69
762. T.M. Davies
1231 S. Lavonne Way
Tucson, AZ. 85713
763. Robert Brown
5117 S. Brookline
Okla City, OK.
73119 '70XR-7
764. Ludvig K. Forberg
Engihlid 7,
Reykjavik, Iceland
'70 Hd p
765. R. Dean Miller c/o
Classic Alley
935 107th ST. Gulf,
Marathon, Fla. 33050
766. Bud Ozmun
RR#1, Spring Creek Rd.
Washington, Ill. 61571
67GT
767. Tim Berns
7956 La Riviera Dr. #157
Sacto, CA. 95826
'68
768. Margo Panozzo
15177 101ST,
Dyer, Ind. 46311
'68 XR-7
769. J.D. Koenig
P.O. Box 560155
Miami, Fla. 33156
770. Tony Klabnik
1400 Greenbrier Rd.
Apt F-14, Anniston, Ala.
36201 '69 conv.
771. J.B. Eckman
7815 Fairmeadow La.
Louisville, KY. 40222
772. Kathy Thompson
516 E. Cook St.
Santa Maria, CA.
93454 '70
773. Randy Nicola
1806 Magnolia
Liberty, MO. 64068
774. Robert Furst
1512 N. 4th St.
Wahpeton, No. Dak.
58075
775. Norman Baldwin
Box 160
Linn, MO. 65051
73 XR conv.
776. Roy Breznik, Auto Restors
3228 Barksdale Blvd.
Bossier City, LA. 71112
'68 & '67
777. Thomas Oswald
RD-3 Box 127
Tamaqua, PA.
18252 69XR-7
778. Robert O'Bryan Jr.
RT. 2 Ralph Ave.
Owensboro, KY. 42301
779. Eric Rasmussen
471 Ord Dr.,
Boulder, CO. 80303

780. Gary Sampson
2940 8th St.,
Marion, IA. 52302
'70 Conv.
781. Thomas Williams Sr.
501 El Rancho Dr. #11
Sparks, Nev. 89431
'68 & '68
782. Tom Johnston
419 North Cass Ave.
Springfield, MN. 56087
783. Kathy Hartman
14027 Castle Blvd. #401
Silver Springs, MD. 20904
'67 XR-7
784. Jerry Gardner
3130 North Mojave
Provo, Utah 84601
67-68
785. Charles Paddock
19130 Audette
Dearborn, MI. 48124
'73 XR-7
786. Richard Hall
5779 Moores Ave.
Newark, CA. 94560
'69 & '71
787. Hon. Robert J. Hallisey
Superior Court House
New Bedford, Mass. 02740
'73 XR-7 Convertible
788. Betty Warren
406 Lorene Dr.,
Marietta, GA. 30060
'72 XR-7
789. Don Pierce
1013 San Mateo
SE, Albuquerque, NM.
87108 '67
790. Brett Haugen
2023-1 N. Kavaney,
Bismark, ND. 58501
'69
791. Michael Remley
7705 Kline Dr.
Arvada, CO. 80005
'67 XR-7GT
792. David Killingsworth
1021 Riverside Dr.,
South Bend, IND. 46616
'70 Elim 428CJ
793. John Koehler
2806 Harvard Rd.
Erie, Pa. 16508
794. Larry Dean Bauer
16624 Chaplin Ave
Encino, CA. 91436
795. Tommy Snell c/o
Med. Arts Center
PO Box 938 1003 Medical Dr.
Killeen, TX. 76541 '69 xr-428
796. William Harwood
3225 Ulmer Rd.
Columbia, S.C. 29209
797. Al Foltz
2230 S.E. 32nd,
Hillsboro, OR. 97123
4-'67s
798. Dan Keough
206 W. Nicolet
Marquette, MI. 49855
'68
799. Dorm Rippie
2303 N. 6th St.,
Blue Springs, MO.
64015
800. Richard Kinney
7221 W 79th St.
P.O. Box 4279,
Overland Park, KS. 66204
'68
801. Roy Bowser
269 S. Jefferson St.
Kittanning, PA. 16201
'69 Eliminator
802. D.L. Phillips
3416 Darrell La,
Missoula, Mont.
'70 Convertible
803. Phil Thompson
652 Fingerboard Rd.
Staaten Island, NY 10305
804. Rick Daniels
1306 W 41 Ave.
Anch., AK. 99503
Apt 2 '68
805. Micheal Smith
30 Towngreen La.
Aughton, Lancashire,
England '68 XR-7GTE
806. Marc Miles
800 Cardinal Circle
Bedford, TX. 76021
807. Robert Wells
300 Williamsburg Dr.
Silver Springs, MD. 20901
'69
808. Paul Whitney
954 E. Olmstead
Evansville, IN.
47711
809. Jim Allman
35-100 Date Palm Dr.
No. 13, Palm Springs, CA.
92264

...all the signs of the bat...

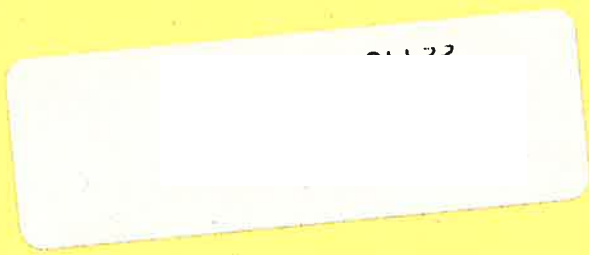

Longman Club of America
1526 Guyan Place
Shore, N.Y. 10861